

Electro-Voice®
a MARK IV company

**Model HP4020
Constant-Directivity
Horn**

SPECIFICATIONS

The following specifications are in accordance with or exceed the AES Recommended Practice for Specification of Loudspeaker Components Used in Professional Audio and Sound Reinforcement (AES2-1984; ANSI S4.26-1984).

Horizontal Beamwidth:
40° (+20°, -10°)
(-6 dB, 500 Hz to 20 kHz)

Vertical Beamwidth:
20° (+20°, -10°)
(-6 dB, 500 Hz to 20 kHz)

Directivity Factor R_0 (Q):
50.9 (average 1.25 kHz to 20 kHz)

Directivity Index D_i :
17.1 dB (+0.6, -1.7 dB)
10 log R_0 , (average 1.25 kHz to 20 kHz)

Usable Lower Frequency Limit:
200 Hz

Construction:

Polyester resin and glass-fiber laminate integrally molded to a die-cast zinc throat section. This hybrid construction assures a rigid driver mount, accurate, loss-free throat-wave transmission and low total weight compared to horns of similar size.

Mechanical Connection of Driver:

Bolt on; standard 2"-diameter throat, 5"-diameter mounting flange and four clearance holes for 1/4" bolts on a 4"-diameter bolt circle.

Recommended Drivers:

DH1
DH2

Dimensions:

81.3 cm (32.0 in.)
83.8 cm (33.0 in.)
125.2 cm (49.3 in.)

Weight:

12.3 kg (27.0 lbs)

Shipping Weight:

18.2 kg (40.0 lbs)

DESCRIPTION

The Electro-Voice model HP4020 is a wide-range, flat-front, high-frequency, constant-directivity horn. It offers economy of space, where its geometry is "just big enough for the job." The horizontal angle is controlled over a frequency range of 500 Hz to 20 kHz and the vertical angle is controlled from 500 Hz to 20 kHz, both with unusual precision and adherence to the intended angle. Furthermore, excellent loading is maintained to a low frequency of 200 Hz. The HP horn series¹ represents the latest development in "CD" horn design, employing the same principles which EV engineers developed and used to design the world's first true constant-directivity horns in 1974. The flat-front design makes the HP4020 suitable for all modern boxed and clustered systems. A unique, lightweight, integral fiberglass-and-zinc construction gives acoustical and mechanical advantages (see Construction section). Lastly, a special vaned waveguide throat detail gives the HP4020 unusually good high-frequency control, vertically, when compared to similar 2-inch-throat horn designs.

1. Patent pending.

R_0 and D_i vs Frequency
(one-third-octave bandwidths)

| Freq. (Hz) | R_0 | D_i (dB) | Freq. (Hz) | R_0 | D_i (dB) |
|------------|-------|------------|------------|-------|------------|
| 500 | 26.16 | 14.18 | 3,150 | 53.54 | 17.29 |
| 630 | 29.53 | 14.70 | 4,000 | 57.78 | 17.62 |
| 800 | 31.05 | 14.92 | 5,000 | 55.82 | 17.47 |
| 1,000 | 33.58 | 15.26 | 6,300 | 54.89 | 17.39 |
| 1,250 | 34.07 | 15.32 | 8,000 | 57.09 | 17.57 |
| 1,600 | 40.61 | 16.09 | 10,000 | 52.28 | 17.18 |
| 2,000 | 37.95 | 15.79 | 12,500 | 52.91 | 17.24 |
| 2,500 | 49.83 | 16.97 | 16,000 | 54.62 | 17.37 |

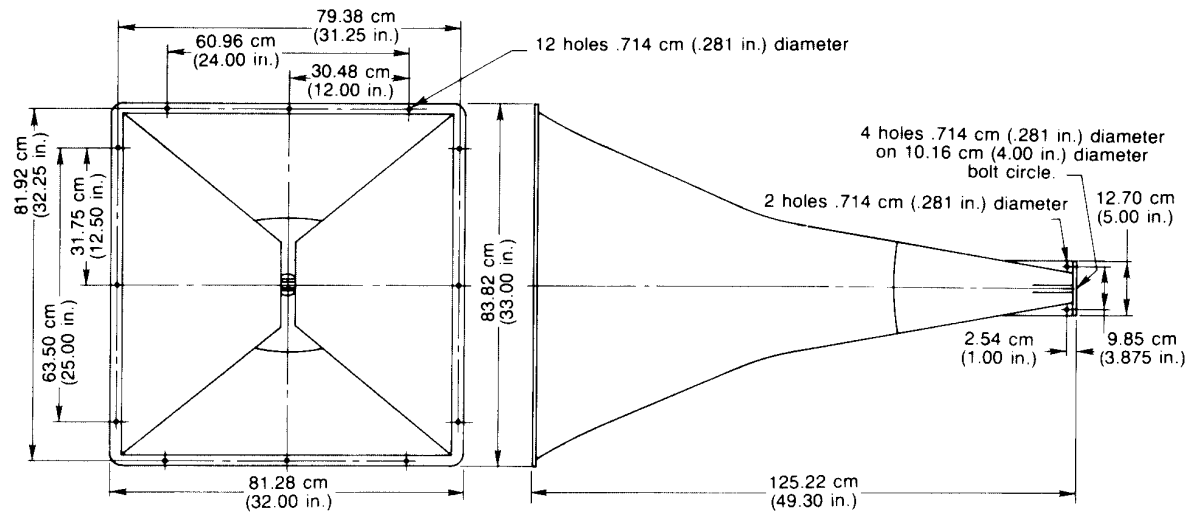

FIGURE 1 — Dimensions

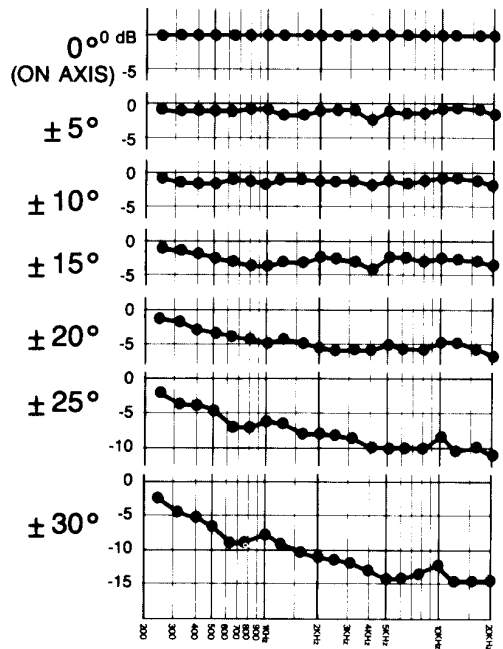

FIGURE 2
Horizontal Off-Axis Response

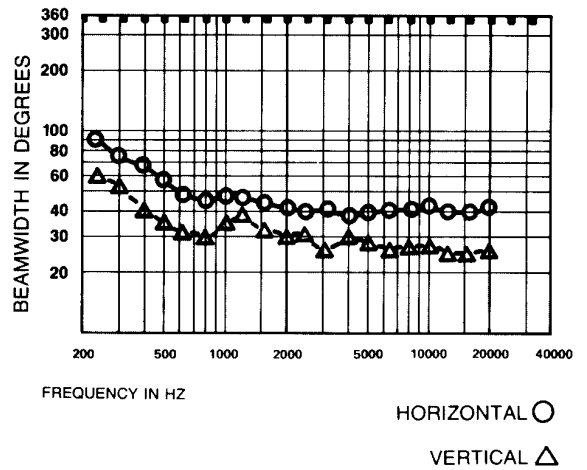

FIGURE 4
6-dB-Down Beamwidth versus Frequency

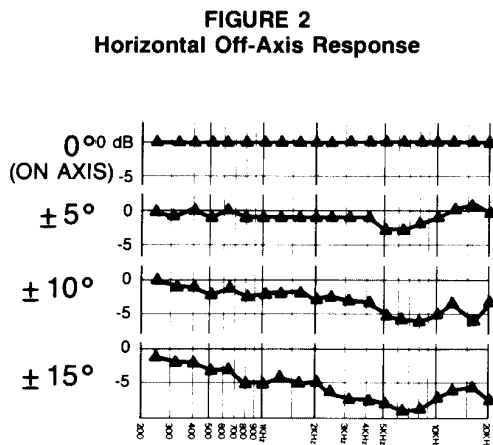

FIGURE 3
Vertical Off-Axis Response

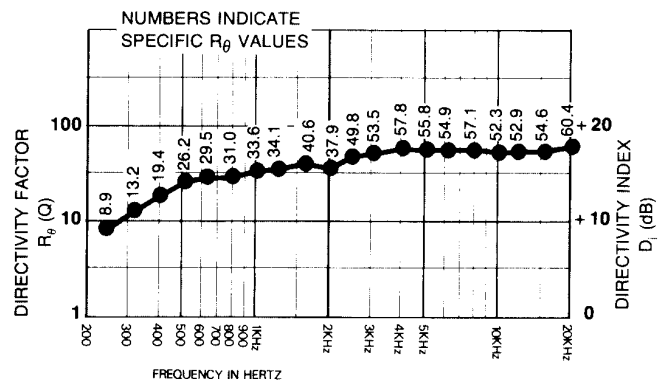
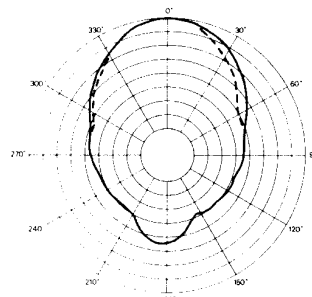
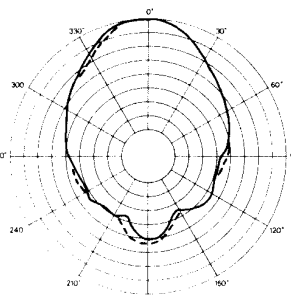

FIGURE 5
Directivity versus Frequency



500HZ



630Hz

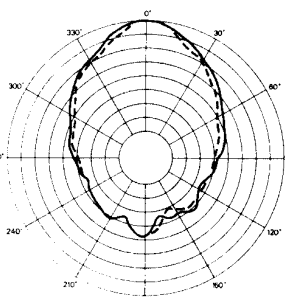

800Hz

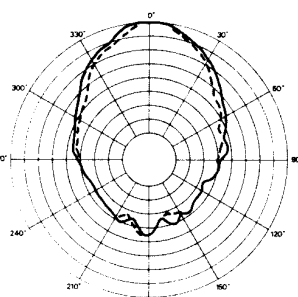

1kHz

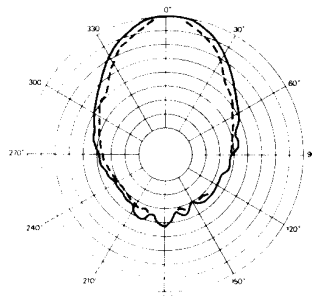

1.25kHz

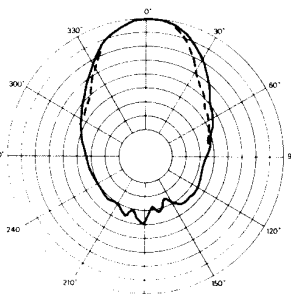

1.6kHz

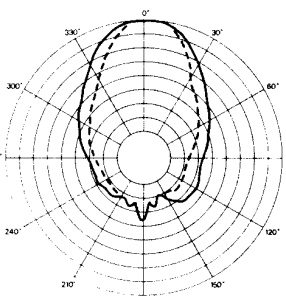

2kHz

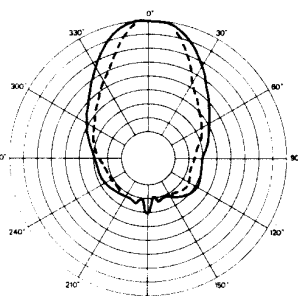

2.5kHz

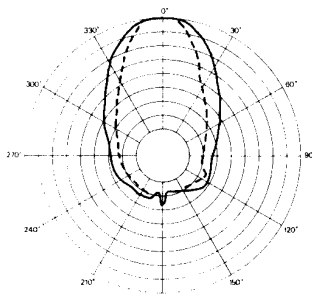

3.15kHz

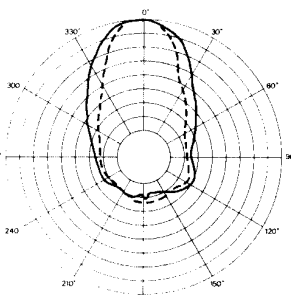

4kHz

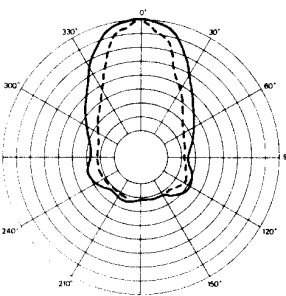

5kHz

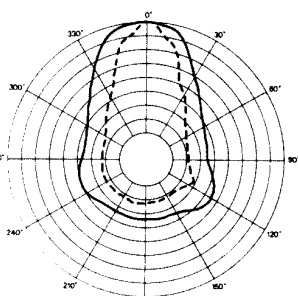

6.3kHz

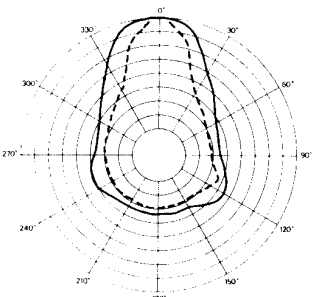

8kHz

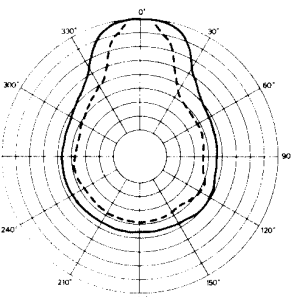

10kHz

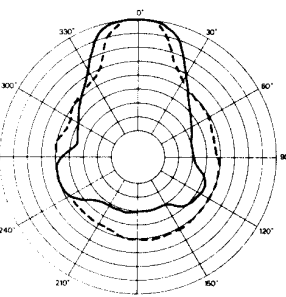

12.5kHz

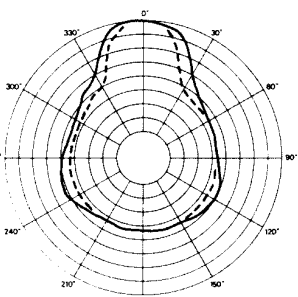

16kHz

Scale is 5dB per division

HORIZONTAL ———
VERTICAL - - - -

FIGURE 6 — Polars

DIRECTIVITY

The axial directivity factor R_0 (formerly Q) of the HP4020 horn was computed at each one-third-octave center frequency from the horizontal/vertical polars which are displayed in Figure 6. The graph in Figure 5 illustrates this data over the range 500 Hz to 20 kHz. The axial frequency response of the HP4020 with a particular driver is in close correspondence to that driver's power response above 500 Hz.

BEAMWIDTH

A plot of the HP4020's 6-dB-down total included beamwidth angle is shown in Figure 4 for each one-third-octave center frequency. The horizontal beamwidth is maintained at 40° (+20°, -10°) over the range 500 Hz to 20 kHz. Vertical beamwidth is maintained at 20° (+20°, -10°) over the range 500 Hz to 20 kHz.

FREQUENCY RESPONSE ON AND OFF AXIS

The one-third-octave frequency response of the HP4020 at various on- and off-axis angles, was derived from the accompanying polars and is displayed in Figure 2 and Figure 3. All curves are referenced to the on-axis level. These responses illustrate the curves one would get with a real-time spectrum analyzer at the different angles if the horn/driver were equalized flat on axis, in an anechoic environment.

POLAR RESPONSE

The directional characteristics of the HP4020 with driver attached were measured by running a set of horizontal/vertical polar responses, in EV's large anechoic chamber, at each one-third-octave center frequency. The test signal was one-third-octave pseudo-random pink noise (1.0-Hz repetition rate)

centered at the indicated frequencies. The measurement microphone was placed 6.1 m (20 ft) from the horn mouth, while rotation was about the waveguide geometric apexes. These axes of rotation are quite close to the apparent (acoustic) apexes across the frequency range of measurement. Errors attributable to the slight differences between the geometric and acoustic apexes are reduced to an inconsequential level by the relatively long, 20-foot measuring distance. The horn was suspended freely with no baffle. The polar plots shown in Figure 6 display the results of these tests. The center frequency and beamwidth angle are noted on each plot. The horizontal beamwidth is shown as a solid line and the vertical beamwidth is shown dashed.

ARCHITECTS' AND ENGINEERS' SPECIFICATIONS

The horn shall be of the constant-directivity type. It shall produce a horizontal beamwidth (6-dB-down angle) of 40 degrees, deviating no more than 20 degrees from this angle over the frequency range 500 to 20,000 Hz. It shall produce a vertical beamwidth of 20 degrees, deviating no more than 20 degrees from this angle over the frequency range 500 to 20,000 Hz. In addition, it shall provide useful acoustic loading at all frequencies above 200 Hz.

The horn shall be of hybrid fiberglass-and-zinc construction. The driver-mounting flange and initial throat section shall be constructed of die-cast zinc and shall be integrally laminated into the fiberglass portion of the horn.

The horn shall possess a throat of 4.92-cm (1.94-in.) diameter and its flange shall be provided with four ¼-20-clearance bolt holes on a 10.2-cm (4.0-in.) circle for the mounting of the compression driver. The horn shall be

83.8 cm (33.0 in.) high, 81.3 cm (32.0 in.) wide, and 125.2 cm (49.3 in.) long. It shall weigh no more than 12.3 kg (27 lb).

The horn shall be the Electro-Voice model HP4020 constant-directivity horn.

WARRANTY (Limited)

Electro-Voice Speakers and Speaker Systems (excluding active electronics) are guaranteed for five years from date of original purchase against malfunction due to defects in workmanship and materials. If such malfunction occurs, unit will be repaired or replaced (at our option) without charge for materials or labor if delivered prepaid to the proper Electro-Voice service facility. Unit will be returned prepaid. Warranty does not extend to finish, appearance items, burned coils, or malfunction due to abuse or operation under other than specified conditions, including cone and/or coil damage resulting from improperly designed enclosures, nor does it extend to incidental or consequential damages. Some states do not allow the exclusion or limitation of incidental or consequential damages, so the above exclusion may not apply to you. Repair by other than Electro-Voice or its authorized service agencies will void this guarantee. A list of authorized warranty service agencies is available from Electro-Voice, Inc., 600 Cecil Street, Buchanan, MI 49107 (AC/616-695-6831); or Electro-Voice West, 8234 Doe Avenue, Visalia, CA 93291 (AC/209-651-7777). This warranty gives you specific legal rights, and you may also have other rights which vary from state to state.

Service and repair address for this product: Electro-Voice, Inc., 600 Cecil Street, Buchanan, Michigan 49107.

Specifications subject to change without notice.