

Electro-Voice®

a MARK IV company

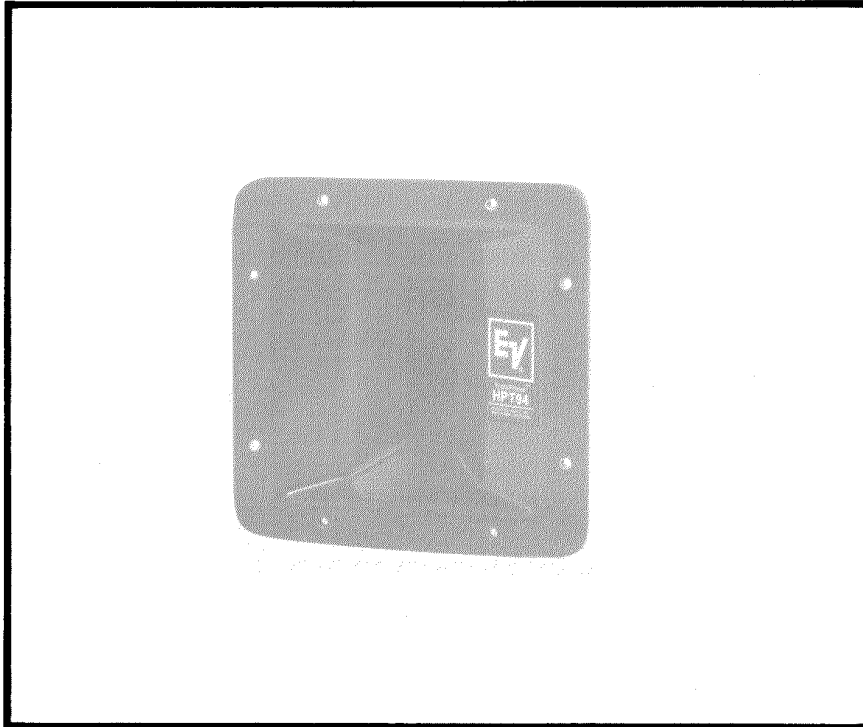

Model HPT94 Constant-Directivity Supertweeter Horn

SPECIFICATIONS

The following specifications are in accordance with or exceed the AES Recommended Practice for Specification of Loudspeaker Components Used in Professional Audio and Sound Reinforcement (AES2-1984; ANSI S4.26-1984).

Horizontal Beamwidth:

90° (+15°, -15°)
(-6 dB, 3 kHz to 20 kHz)

Vertical Beamwidth:

40° (+20°, -10°)
(-6 dB, 4 kHz to 20 kHz)

Directivity Factor R_θ (Q):

11.6 (average 3 kHz to 20 kHz)

Directivity Index D_i :

10.6 dB (+1.6, -1.0 dB)
10 log R_θ , (average 3 kHz to 20 kHz)

Usable Lower Frequency Limit:

1.6 kHz

Construction:

Polyester resin and glass-fiber laminate integrally molded to a die-cast zinc throat section. This hybrid construction assures a rigid driver mount, accurate, loss-free throat-wave transmission and low total weight compared to horns of similar size.

Mechanical Connection of Driver:

1 $\frac{3}{8}$ "-18 thread allows the attachment of the DH3 or DH2MT drivers

Recommended Driver:

DH3

Dimensions:

13.3 cm (5.3 in.) wide
13.3 cm (5.3 in.) high
10.4 cm (4.1 in.) deep

Weight:

0.4 kg (0.8 lb)

Shipping Weight:

0.5 kg (1.1 lb)

DESCRIPTION

The Electro-Voice model HPT94 is a wide-range, flat-front, constant-directivity supertweeter horn. It offers economy of space, where its geometry is "just big enough for the job." Both horizontal and vertical angles are controlled from 3 kHz to 20 kHz with unusual precision and adherence to the intended angle. Furthermore, excellent loading is maintained to 1,600 Hz. The HPT horn series represents the latest development in "CD" horn design, employing the same principles which EV engineers developed and used to design the world's first true constant-directivity horns in 1974. The flat-front design makes the HPT94 suitable for all modern boxed and clustered systems. A unique, lightweight, integral fiberglass-and-zinc construction gives acoustical and mechanical advantages (see Construction section).

R_θ and D_i vs Frequency
(one-third-octave bandwidths)

Freq. (Hz)	R_θ	D_i (dB)	Freq. (Hz)	R_θ	D_i (dB)
3,150	9.38	9.72	10,000	13.24	11.22
4,000	9.69	9.86	12,500	13.56	11.32
5,000	9.14	9.61	16,000	12.05	10.81
6,300	9.83	9.92	20,000	16.64	12.21
8,000	10.98	10.40			

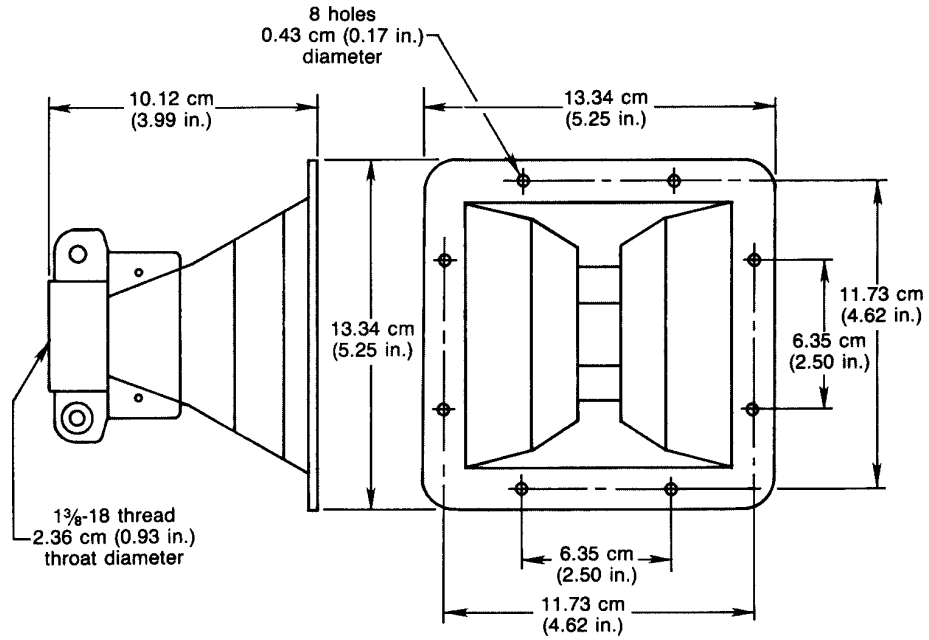

FIGURE 1 — Dimensions

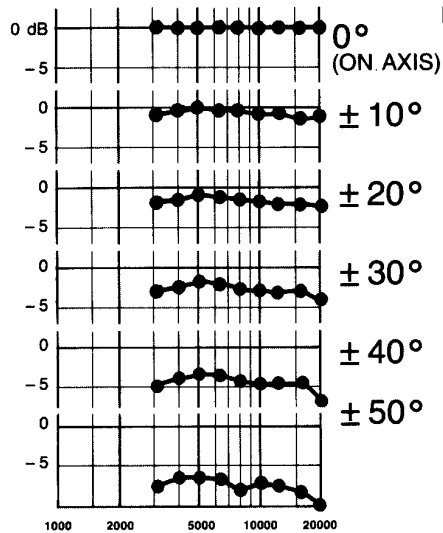

FIGURE 2
Horizontal Off-Axis Response

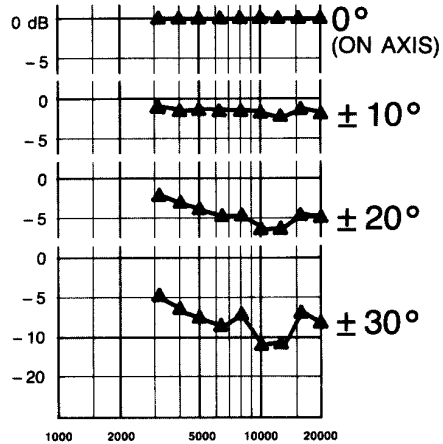

FIGURE 3
Vertical Off-Axis Response

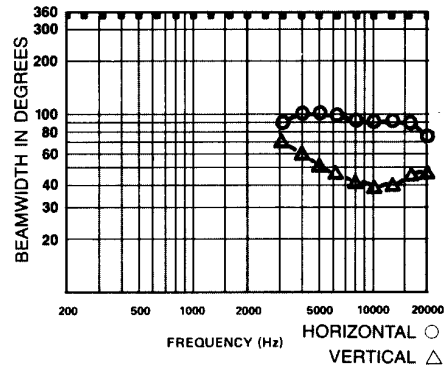

FIGURE 4
6-dB-Down Beamwidth versus Frequency

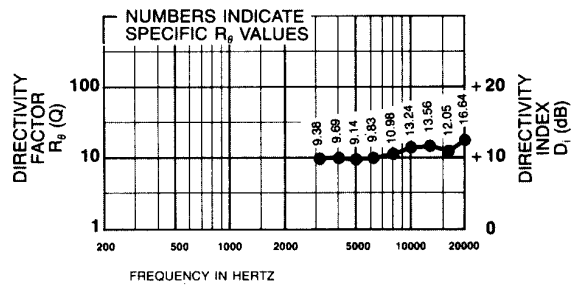

FIGURE 5
Directivity versus Frequency

DIRECTIVITY

The axial directivity factor R_0 (formerly Q) of the HPT94 horn was computed at each one-third-octave center frequency from the horizontal/vertical polars which are displayed in Figure 6. The graph in Figure 5 illustrates this data over the range 3 kHz to 20 kHz. The axial frequency response of the HPT94 horn with a particular driver is in close correspondence to that driver's power response above 3 kHz.

BEAMWIDTH

A plot of the HPT94's 6-dB-down total included beamwidth angle is shown in Figure 4 for each one-third-octave center frequency. The horizontal beamwidth is maintained at 90° (+ 15°, - 15°) over the range 3 kHz to 20 kHz. Vertical beamwidth control occurs only above 4 kHz.

FREQUENCY RESPONSE ON AND OFF AXIS

The one-third-octave frequency response of the HPT94 at various on- and off-axis angles, was derived from the accompanying polars and is displayed in Figure 2 and Figure 3. All curves are referenced to the on-axis level. These responses illustrate the curves one would get with a real-time spectrum analyzer at the different angles if the horn/driver were equalized flat on axis, in an anechoic environment.

POLAR RESPONSE

The directional characteristics of the HPT94 with driver attached were measured by running a set of horizontal/vertical polar responses in EV's large anechoic chamber, at each one-third-octave center frequency. The test signal was one-third-octave pseudo-

random pink noise centered at the indicated frequencies. The measurement microphone was placed 6.1 m (20 ft) from the horn mouth, while rotation was about the waveguide geometric apexes. These axes of rotation are quite close to the apparent (acoustic) apexes across the frequency range of measurement. Errors attributable to the slight differences between the geometric and acoustic apexes are reduced to an inconsequential level by the relatively long, 20-foot measuring distance. The horn was suspended freely with no baffle. The polar plots shown in Figure 6 display the results of these tests. The center frequency is noted on each plot. The wider plot on each chart is the horizontal polar (—) and the narrower plot is the vertical polar (- - -).

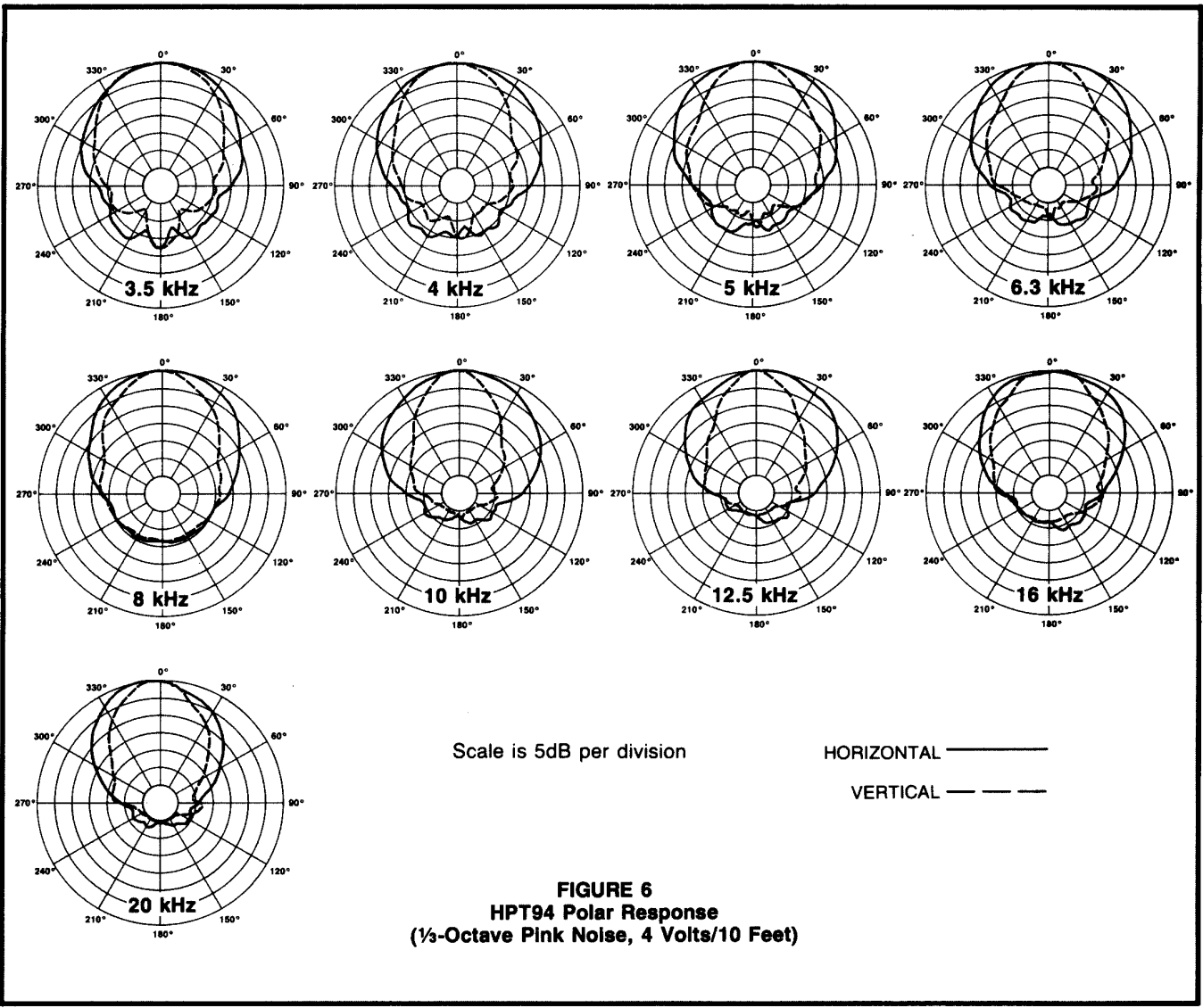

**ARCHITECTS' AND ENGINEERS'
SPECIFICATIONS**

The horn shall be of the constant-directivity type. It shall produce a horizontal beamwidth (6-dB-down angle) of 90 degrees, deviating no more than 15 degrees from this angle over the frequency range 3 kHz to 20 kHz. It shall produce a vertical beamwidth of 40 degrees, deviating no more than 20 degrees from this angle over the frequency range 4 kHz to 20 kHz. In addition, it shall provide useful acoustic loading at all frequencies above 1.6 kHz.

The horn shall be of hybrid fiberglass-and-zinc construction. The initial throat section shall be constructed of die-cast zinc and shall be integrally laminated into the fiberglass portion of the horn.

The horn shall possess a throat of 2.36-cm (0.93-in.) diameter and shall be provided with a 1- $\frac{3}{8}$ "-18 thread for the mounting of a compression driver. The horn shall be 13.3

cm (5.3 in.) high, 13.3 cm (5.3 in.) wide, and 10.1 cm (4.0 in.) long. It shall weigh no more than 1.8 kg (0.8 lb).

The horn shall be the Electro-Voice model HPT94 constant-directivity horn.

WARRANTY (Limited)

Electro-Voice Speakers and Speaker Systems (excluding active electronics) are guaranteed for five years from date of original purchase against malfunction due to defects in workmanship and materials. If such malfunction occurs, unit will be repaired or replaced (at our option) without charge for materials or labor if delivered prepaid to the proper Electro-Voice service facility. Unit will be returned prepaid. Warranty does not extend to finish, appearance items, burned coils, or malfunction due to abuse or operation under other than specified conditions, including cone and/or coil damage resulting from improperly designed enclosures, nor does it extend to incidental or consequential

damages. Some states do not allow the exclusion or limitation of incidental or consequential damages, so the above exclusion may not apply to you. Repair by other than Electro-Voice or its authorized service agencies will void this guarantee. A list of authorized warranty service agencies is available from Electro-Voice, Inc., 600 Cecil Street, Buchanan, MI 49107 (AC/616-695-6831); or Electro-Voice West, 8234 Doe Avenue, Visalia, CA 93291 (AC/209-651-7777). This warranty gives you specific legal rights, and you may also have other rights which vary from state to state.

Service and repair address for this product: Electro-Voice, Inc., 600 Cecil Street, Buchanan, Michigan 49107.

Specifications subject to change without notice.