

## MH6040AC Coaxial Constant-Directivity Manifold Technology® Horn System

- For high-performance speech and music systems in large venues, indoors and out
- Includes HP640 high-frequency horn and mounting brackets
- Midrange covered by two 10-inch DL10X-SH drivers manifolded on a 60° x 40° constant-directivity horn.
- Response to 100 Hz eliminates supplemental low-frequency systems in many applications
- Large mouth has high directivity at low frequencies
- Ring-Mode Decoupling (RMD™) for outstanding intelligibility

### Description

The Electro-Voice MH6040AC is a wide-range, 60° x 40° mid-bass/high-frequency constant-directivity horn-and-driver system. With a contractor-installed high-frequency driver, it covers the frequency range of 100 Hz to 20,000 Hz with minimal equalization. The MH6040AC combines two world-pioneering concepts developed by Electro-Voice: constant-directivity horns and Manifold Technology®. The MH6040AC's potentially high acoustic output, stable directional characteristics, and extended low-frequency performance make it highly suitable for music and speech reinforcement in large indoor and outdoor venues.

At the heart of the MH6040AC are two DL10X-SH 10-inch water-resistant drivers (U.S. Patent No. 4,547,632). The driver has been specially developed for the MH series of horns. It incorporates a unique diaphragm construction of Kevlar® and epoxy.<sup>1</sup> This combination of high-technology materials produces a diaphragm with a strength-to-weight ratio on the order of twice that of conventional materials. Each driver is integrally mounted to the fiberglass horn bell via a heavy-duty mounting bracket and propri-

etary Aperiodic Enhancer™ phase plug.

Manifolding allows the output of two or more drivers to be summed without the usual detrimental interference problems in the pass-band. There are a number of additional advantages to manifolding, including reduced distortion (see Figure 5) and increased efficiency at certain frequencies. There is also redundancy built into the system; in the unlikely event of a driver failure, one remains available. The DLX10-SH drivers are contained and sealed within fiberglass covers optimally tuned for maximum low-end performance and displacement control.

The frequencies above 1,250 Hz are handled by the Electro-Voice HP640 constant-directivity horn, in combination with a contractor-selected-and-installed high-frequency compression driver.

### Ring-Mode Decoupling (RMD™) Technology

The MH6040AC controls both acoustical and mechanical ring modes to provide dramatically increased intelligibility, using techniques learned from the development of the Electro-Voice X-Array concert speakers. There is much less coloration of the sound from resonating sources, leaving only the

intended sound to be heard by the audience.

### Installation

The MH6040AC is designed to be suspended safely and easily. The integral mounting brackets at the rear should be used as the main structural hanging location. There are also two structural hanging locations on the rear of the front flange to aim and stabilize the device. Electro-Voice recommends that each MH6040AC be independently supported. The MH6040AC can be easily suspended with either the 60° or the 40° coverage pattern horizontal. Note: the contractor-selected high-frequency drivers contribute to the overall weight of the MH6040AC. In the worst case (DH2A/4MT) an additional 48 lb is added. This should be taken into consideration when suspending the system.

It is recommended that the MH6040AC be mounted with the horn mouth angled at least 10 degrees down from horizontal. This will prevent any water that may get into the mouth of the horn from being funneled to the area of the woofers.

Electrical connections can be made using standard electrical boxes or weather-resistant boxes if used in adverse conditions. The mounting brackets incorporate a predrilled

1. Kevlar® is a registered trademark of Du Pont.

flange to aid electrical box mounting.

If the MH6040AC is suspended, it is recommended that the unit be inspected at least once a year. If any sign of weakness is detected, remedial action should be taken immediately.

---

## Equalization and Subpassband Protection

---

The MH6040AC's mid-bass section exhibits typical constant-directivity horn characteristics, i.e., roll-off at the frequency extremes. At higher frequencies, the roll-off approximately matches the power-response of the DL10X-SH (6 dB per octave). At lower frequencies, directivity is lost when the mouth is no longer large enough to maintain directional control. These two consequences can be observed in the "humped" response in Figure 3. Equalization can be easily applied with a graphic equalizer to give a flat response.

The high-frequency compression driver can be equalized with a graphic equalizer or an EQ module inserted into the Electro-Voice XEQ-2 (two-way) or XEQ-3 (two-way or three-way) active crossover/equalizer. The EQ module should be selected to suit the particular compression driver and the HP640 horn (see relevant data sheet). Because of its use in large arenas, where air loss can be significant, it is recommended that the system be equalized "on site" for optimum results. The XEQ-3 and the mid-bass EQ module from the EQMT-2 can be used to provide a good starting point for the equalization.

Electro-Voice strongly recommends the use of a 100-Hz high-pass filter to protect the drivers from unnecessary excursion and thermal stress.

---

## Directivity

---

The axial directivity factor  $R_q$  of the MH6040AC was computed at each of the one-third-octave center frequencies over the frequency range noted from the horizontal/vertical polars shown in Figure 7. Directivity index ( $D_i$ ) was taken over the same frequency range.

---

## Beamwidth

---

Plots of the MH6040AC's 6-dB-down total included beamwidth angles are shown in Figure 6 for each of the one-third-octave center frequencies noted.

---

## Polar Response

---

The directional characteristics of the MH6040AC were obtained by selecting the horizontal and vertical details from a full set of polar data measured in EV's large anechoic chamber. The measurement microphone was placed 6.1 m (20 ft) from the center of rotation of the horn which, in turn, is 0.94 m (3.08 ft) behind the mouth of the horn. See Figure 1.

---

## Polarity of the DL10X-SH Drivers

---

For Manifold Technology<sup>®</sup> to operate correctly, the drivers must be operated "in phase." In other words, for parallel connection, the DL10X-SH's must be connected so the negative terminals of the drivers are connected together, and the positive terminals are connected together.

---

## Service

---

In the unlikely event the MH6040AC requires service, each DL10X-SH easily can be replaced or serviced by removing the back cover and then removing the driver. A service data sheet is available from Electro-Voice.

---

## Power Handling Capacity

---

To our knowledge, Electro-Voice was the first U.S. manufacturer to develop and publish a power test closely related to real-life conditions. A random-noise input signal is used because it contains many frequencies simultaneously, just like real voice or instrument program. The signal contains more energy at extremely high and low frequencies than typical actual program, adding an extra margin of reliability. The test combines not only the overall "long-term average" or "continuous" level—which our ears interpret as loudness—but also short-duration peaks which are many times higher than average, just like actual program. The long-term average level stresses the speaker thermally

(heat). The instantaneous peaks test mechanical reliability (cone excursion). Note that the sine-wave test signals sometimes used have a much less demanding peak value relative to their average level. In actual use, long-term average levels exist from several seconds on up. The test performed lasts for eight hours, adding another extra level of confidence.

Specifically, the MH6040AC mid-band section is designed to withstand the power test described in EIA Standard RS-426A. The EIA test spectrum is applied for eight hours. The spectrum is obtained by filtering white noise (a particular type of random noise with equal energy per bandwidth). The filter applies 6-dB-per-octave slopes below 40 Hz and above 318 Hz. When measured with a one-third-octave constant-percentage analyzer, this filter produces a spectrum whose 3-dB-down points are at 100 Hz and 1,200 Hz with a 3-dB-per-octave slope above 1,200 Hz. This shaped signal is then further filtered with an 80-Hz, 12-dB-per-octave high-pass filter to prevent out-of-passband displacement. The amplifier is set to provide 600 watts into the 3.45-ohm EIA equivalent impedance (45.5 volts). Amplifier clipping sets instantaneous peaks at 6 dB above the continuous power or 2,400 watts peak (91.0 volts). During this test, the mid-band section is not high passed at 1,250 Hz. The high-frequency section's power handling is dependent on the selected driver combination. Please refer to the relevant engineering data sheet.

---

## Architects' and Engineers' Specifications

---

The horn shall be of the constant-directivity type. It shall produce a horizontal beamwidth (6-dB-down angle) of  $-60^\circ$ , deviating no more than  $+10^\circ$  or  $-20^\circ$  from this angle over the range of 400 Hz to 20 kHz. It shall produce a vertical beamwidth of  $40^\circ$ , deviating no more than  $+20^\circ$  or  $-15^\circ$  over the frequency range of 325 Hz to 20 kHz. In addition, it shall provide an acoustic load to below 100 Hz.

The MH6040AC mid-bass section shall operate over the range of 100 Hz to 4,000 Hz, with a recommended crossover frequency of

# MH6040AC Coaxial Constant-Directivity Manifold Technology® Horn System

1,250 Hz, and be driven by two 10-inch, weather-resistant drivers with high-technology cones of Kevlar® and epoxy.<sup>1</sup> The patented Manifold Technology® technique shall be exploited and result in a power-handling capacity of 600 watts per EIA Standard RS-426. The average axial sensitivity shall be 105 dB SPL at 1 meter with 2.83 volts applied. The frequencies above 1,250 Hz shall be produced by the supplied Electro-Voice HP640 TransPlanar™ constant-directivity horn with user-selectable driver combinations.

The horn bell manifold chamber and back covers shall be constructed of fiberglass, foam and polyester resin. Two steel mounting rails shall be provided to coaxially mount the Electro-Voice HP640 horn. The horn shall have an integral rear mounting bracket made of black powder-coated 10-gauge steel. Brackets shall be provided at the front of the horn to stabilize and aim the MH6040AC.

The horn shall be 149.9 cm (59.0 in.) high, 99.1 cm (39.0 in.) wide, 153.4 cm (60.4 in.) long and weigh 75 kg (165 lb).

The horn shall be the Electro-Voice MH6040AC coaxial constant-directivity Manifold Technology® horn.

## Limited Warranty

Electro-Voice products are guaranteed against malfunction due to defects in materials or workmanship for a specified period, as noted in the individual product-line statement(s) below, or in the individual prod-

uct data sheet or owner's manual, beginning with the date of original purchase. If such malfunction occurs during the specified period, the product will be repaired or replaced (at our option) without charge. The product will be returned to the customer prepaid. **Exclusions and Limitations:** The Limited Warranty does not apply to: (a) exterior finish or appearance; (b) certain specific items described in the individual product-line statement(s) below, or in the individual product data sheet or owner's manual; (c) malfunction resulting from use or operation of the product other than as specified in the product data sheet or owner's manual; (d) malfunction resulting from misuse or abuse of the product; or (e) malfunction occurring at any time after repairs have been made to the product by anyone other than Electro-Voice Service or any of its authorized service representatives. **Obtaining Warranty Service:** To obtain warranty service, a customer must deliver the product, prepaid, to Electro-Voice Service or any of its authorized service representatives together with proof of purchase of the product in the form of a bill of sale or receipted invoice. A list of authorized service representatives is available from Electro-Voice Service at 600 Cecil Street, Buchanan, MI 49107 (800/234-6831 or FAX 616/695-4743). **Incidental and Consequential Damages Excluded:** Product repair or replacement and return to the customer are the only remedies provided to

the customer. Electro-Voice shall not be liable for any incidental or consequential damages including, without limitation, injury to persons or property or loss of use. Some states do not allow the exclusion or limitation of incidental or consequential damages so the above limitation or exclusion may not apply to you. **Other Rights:** This warranty gives you specific legal rights, and you may also have other rights which vary from state to state.

**Electro-Voice Speakers and Speaker Systems** are guaranteed against malfunction due to defects in materials or workmanship for a period of five (5) years from the date of original purchase. The Limited Warranty does not apply to burned voice coils or malfunctions such as cone and/or coil damage resulting from improperly designed enclosures. Electro-Voice active electronics associated with the speaker systems are guaranteed for three (3) years from the date of original purchase. Additional details are included in the Uniform Limited Warranty statement.

**For warranty repair** or service information, contact the service repair department at: 616/695-6831 or 800/685-2606.

**For technical assistance,** contact Technical Support at 800/234-6831 or 616/695-6831, M-F, 8:00 a.m. to 5:00 p.m. Eastern Standard Time.

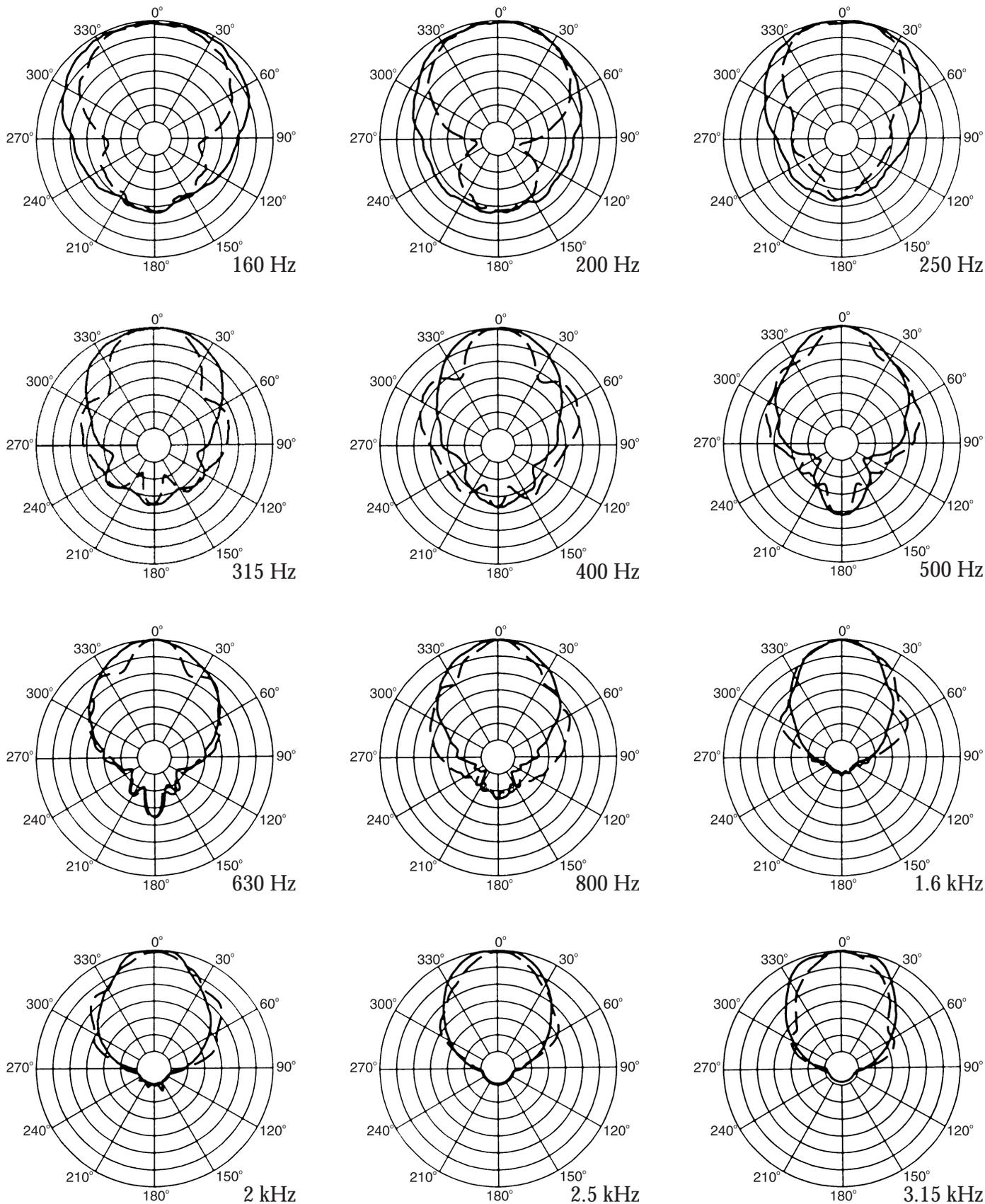
Specifications subject to change without notice.

# MH6040AC Coaxial Constant-Directivity Manifold Technology<sup>®</sup> Horn System

Figure 1—Polar Response

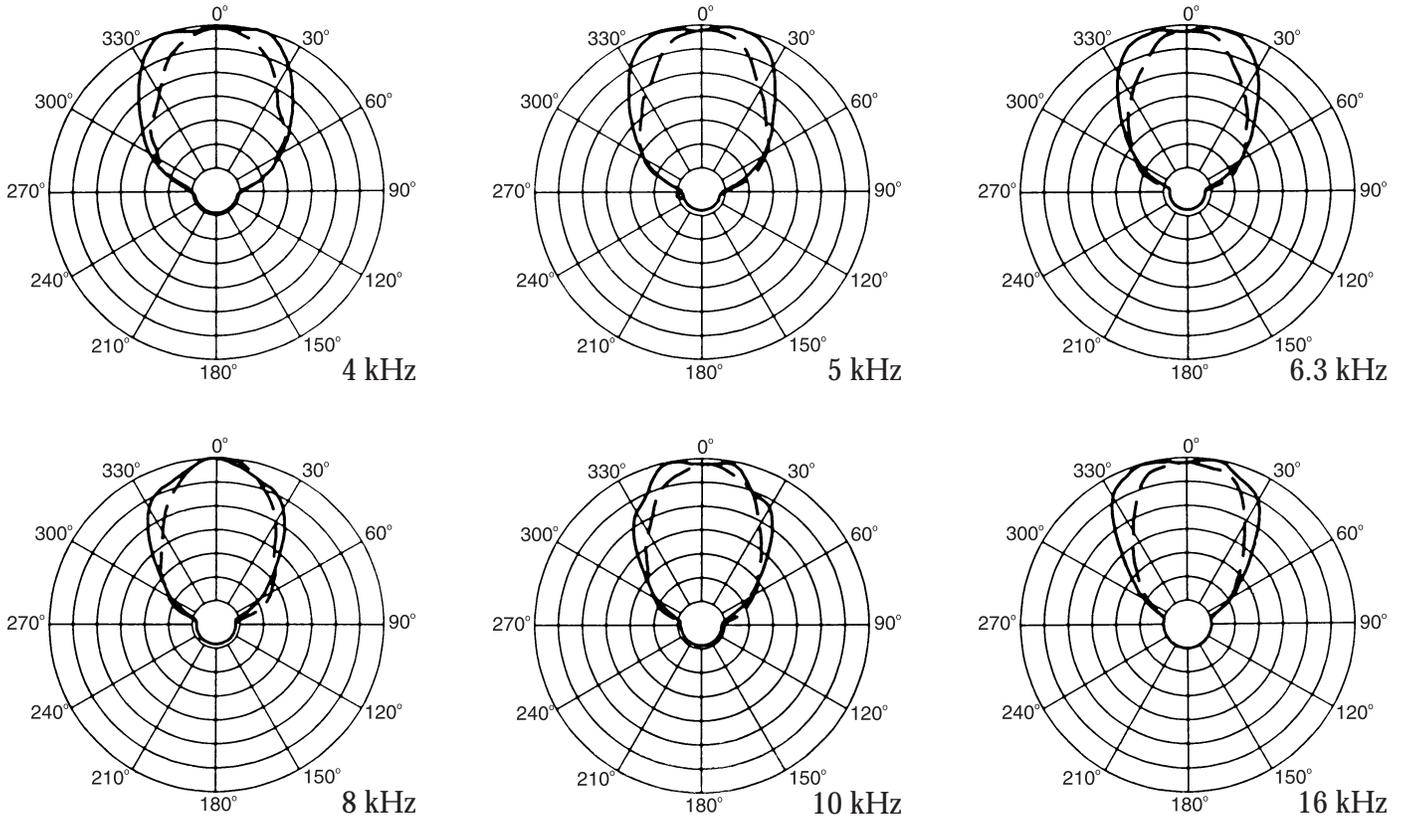
— HORIZONTAL  
 - - - VERTICAL  
 5 dB per division

MH6040AC Coaxial Constant-Directivity Manifold Technology<sup>®</sup> Horn System

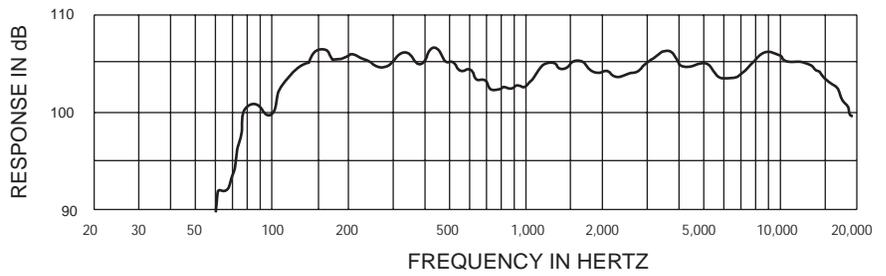


# MH6040AC Coaxial Constant-Directivity Manifold Technology<sup>®</sup> Horn System

MH6040AC Coaxial Constant-Directivity Manifold Technology<sup>®</sup> Horn System

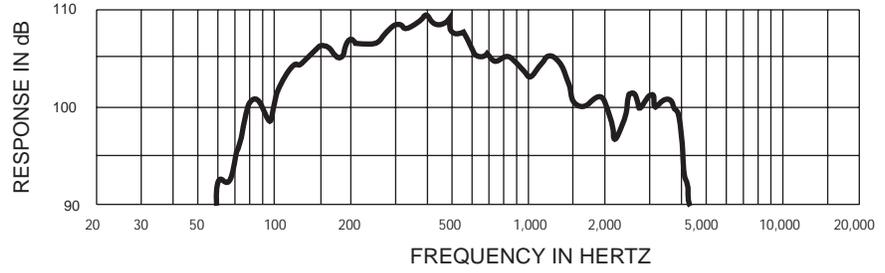


**Figure 2—Typical Axial Frequency Response (with EQ)**

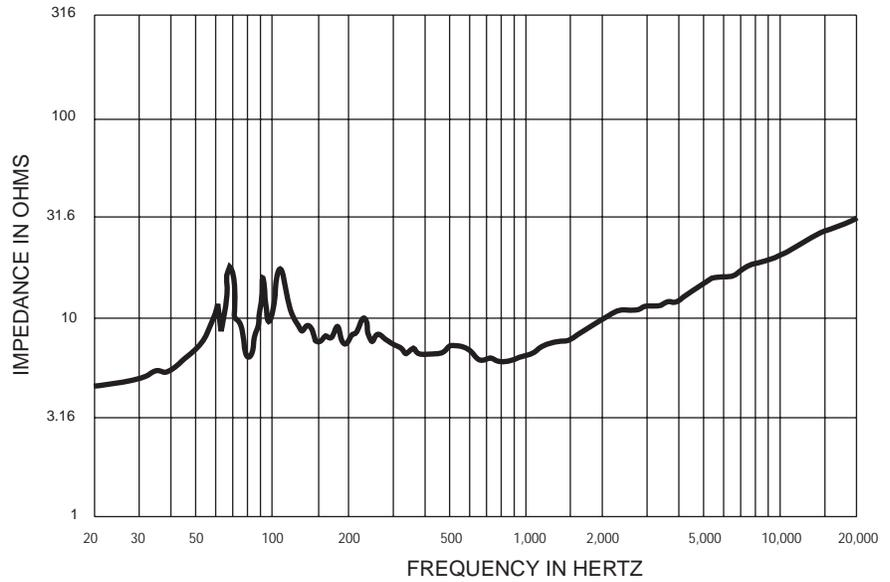


# MH6040AC Coaxial Constant-Directivity Manifold Technology® Horn System

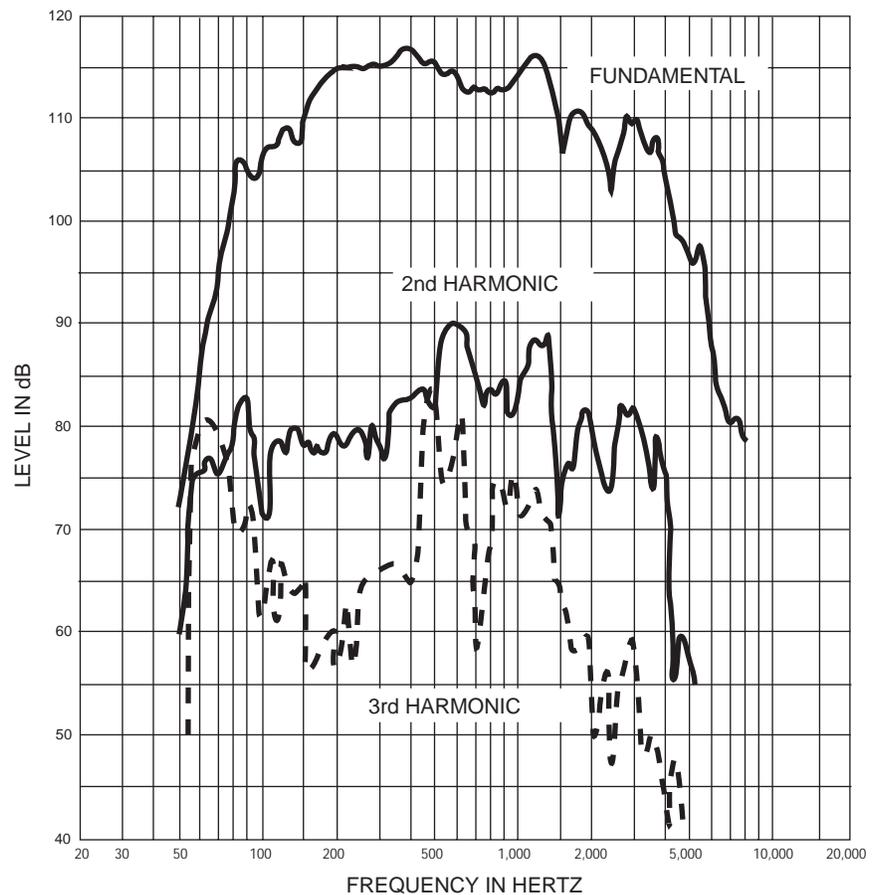
**Figure 3—Axial Frequency Response (1 watt/1 meter), MB Horn Alone**



**Figure 4—Impedance Response, MB Horn Alone**



**Figure 5—Distortion Response, 10% Power, MB Horn Alone**



# MH6040AC Coaxial Constant-Directivity Manifold Technology® Horn System

MH6040AC Coaxial Constant-Directivity Manifold Technology® Horn System

Figure 6—Beamwidth Response

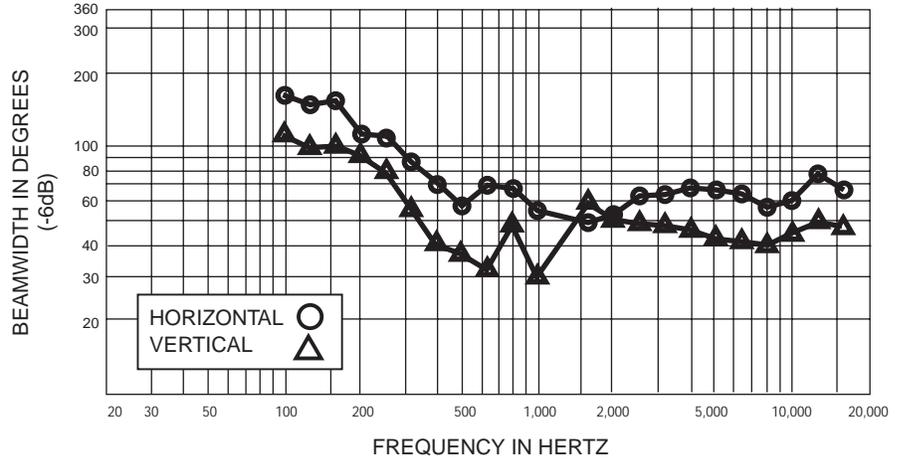


Figure 7—Directivity Response

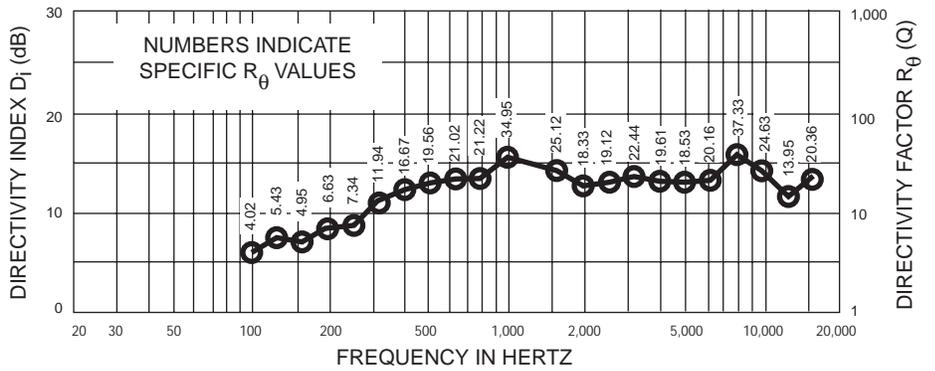
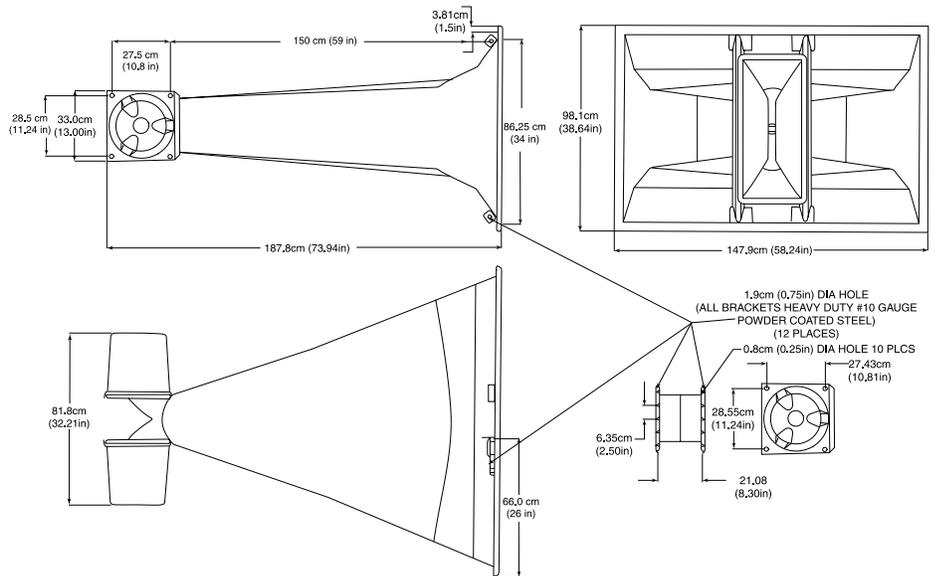


Figure 8—Dimensions



# MH6040AC Coaxial Constant-Directivity Manifold Technology® Horn System

## Specifications:

The following specifications are in accordance with or exceed the AES Recommended Practice for Specifications of Loudspeaker Components Used in Professional Audio and Sound Reinforcement Systems (AES2-1984; ANSI S4.26-1984).

**Frequency Response, Measured in Far Field, Calculated to One Watt at One Meter on Axis, Swept One-Third-Octave Pink Noise, Anechoic Environment,**

**Coaxial Version (see Figure 2):**

100 - 20,000 Hz

**Non-Coaxial Version (see Figure 3):**

100 -4,000 Hz

**Low-Frequency 3-dB-Down Point:**

150 Hz

**Usable Low-Frequency Limit**

**(10-dB-Down Point):**

100 Hz

**Average Efficiency:**

25%

**Long-Term Average Power Handling**

**Capacity per EIA RS-426A**

**(see Power Handling section):**

600 watts

**Maximum Long-Term Mid-Band**

**Acoustic Output:**

150 watts

**Sensitivity, 1 Watt (into nominal impedance) at 1 Meter, Anechoic Environment, Band-Limited Pink-Noise Signal:**

107 dB

**Dispersion Angle Included by 6-dB-Down Points on Polar Responses, Indicated One-Third-Octave Bands of Pink Noise,**

**200 Hz to 20,000 Hz, Horizontal**

**(see Figure 6):**

60° (+10°, -30°)

**315 Hz to 20,000 Hz, Vertical**

**(see Figure 6):**

40° (+20°, -15°)

**Directivity Factor  $R_q(Q)$ , 500 Hz–20,000 Hz Median (see Figure 7):**

24.0

**Directivity Index  $D_i$  (10 log  $R_q$ ), 500 Hz to 20,000 Hz Median (see Figure 7):**

13.8 dB (+0.9, -1.1 dB)

**Transducer Complement:**

Two DL10X-SH manifold drivers with Kevlar® epoxy composite cones<sup>1</sup>

**System Impedance, Drivers in Parallel, Nominal/Minimum (mid-bass section):**

8.0/5.9 ohms

**Polarity:**

A positive voltage applied to the positive (+) sides of the DL10X-SH input cables produces a positive acoustic pressure in the horn throat

**Construction,**

**Main Horn Bell and Driver Back**

**Covers:**

One-piece black polyester and fiberglass laminate with composite reinforcement

**Hanging Hardware:**

Integral black 10-gauge polyester powder-coated steel

**Mechanical Driver Protection:**

Integral grille/protection screen built into the manifold chamber

**Coaxial Horn Supplied (mounted in horn mouth on two steel rails):**

HP640

**High-Frequency Drivers and Driver-Manifold Systems for Coaxial HP640 Horn (contractor selected and installed):**

DH1A, DH1A/2MT, DH2A, DH2A/4MT, N/DYM<sup>®</sup>1 and N/DYM<sup>®</sup>1/2MT

**Input Connections,**

**DL10X-SH:**

Heavy-duty 12-AWG oxygen-free copper cable, unterminated, in exterior grade UV-stabilized flexible conduit

**High-Frequency Driver(s):**

Heavy-duty 12-AWG oxygen-free copper cable, unterminated, in exterior grade UV-stabilized flexible conduit

**Recommended Crossover,**

**Frequency:**

1,250 Hz

**Slope:**

24 dB per octave

**Recommended High-Frequency**

**Driver Delay:**

2.96 msec ±0.3 ms

**Dimensions (see Figure 8),**

**Height:**

149.9 cm (59.0 in.)

**Width:**

99.1 cm (39.0 in.)

**Length:**

187.3 cm (73.9 in.)

**Packed Length:**

203.2 cm (80.0 in.)

**Weight:**

75 kg (165 lb)<sup>2</sup>

**Shipping Weight:**

80 kg (176 lb)

**Packing:**

Wooden pallet

1. Kevlar® is a registered trademark of Du Pont.

2. Without high-frequency drivers (see Installation section).

## Electro-Voice®

600 Cecil Street, Buchanan, MI 49107

616/695-6831, 616/695-1304 Fax