

## MH640P

### Full-Range Horn System with Passive Crossover

- High-output/high-quality music and speech for stadium and performing arts venues
- Short throw/fill-in when used with the very-large-format MH stadium horns
- Large, horn mouth provides uniform directivity control to 500 Hz, for increased intelligibility under difficult acoustic conditions
- Integral suspension system for safe and easy installation
- Ring-Mode Decoupling (RMD™) Technology for outstanding intelligibility and clarity

---

#### Description

---

The Electro-Voice MH640P is a two-way horn-loaded speaker system for permanent installation. Because the mouth dimensions of both the mid-bass and high-frequency horns were correctly chosen and are large enough with respect to the wavelengths reproduced, the MH640P provides uniform directivity control down to 500 Hz. This superior directivity control increases speech intelligibility and musical clarity in difficult acoustic environments. Other horn systems with smaller radiating areas simply cannot provide the high degree of directional control associated with the MH640P.

Delivering smooth and extended performance, the high-frequency section operates from 1,600 to 20,000 Hz and consists of a specially developed, low-profile DH2As2 compression driver coupled to an HP64 60° x 40° constant-directivity horn. The HP64 horn features integral fiberglass and zinc construction for exceptional strength and performance. Beamwidth control vanes in the horn throat correct all coverage anomalies in the 10 to 20 kHz octave. This horn and driver combination is securely mounted to the mid-bass horn by a heavy-duty steel bracket.

The mid-bass system is composed of a DL10X-SH 24.5-cm (10-in.) reproducer mounted on an MH640 60° x 40° mid-bass horn. The DL10X-SH reproducer contains a Kevlar® epoxy cone, which is twice as strong as a conventional paper cone.<sup>1</sup> The mid-bass section operates between 140 and 1,600 Hz, and features a proprietary phase plug (U.S. patent no. 4,718,517) which extends the high-end output to blend seamlessly into the coaxial high-frequency section.

If the MH640P is used in a full-range application, additional low-frequency reinforcement, such as the PI115L or a TL-series enclosure, may be required.

---

#### Ring Mode Decoupling (RMD™)

---

The MH640P controls both acoustical and mechanical ring modes to provide dramatically increased intelligibility, using techniques learned from the development of the Electro-Voice X-Array™ concert speakers. There is much less coloration of the sound from resonating sources, leaving only the intended sound to be heard by the audience.

---

#### Applications

---

The MH640P has been designed specifically with the permanent installation market in

mind. Sports arenas, performing arts centers, auditoriums and large gymnasiums are all candidates for the MH640P. With its superior directivity control, the MH640P is a system that can be used in almost any situation. The concert-sound pedigree of the MH640P is evident by the ease of installation and by the use of professional-grade components throughout the line.

---

#### Suspending MH640P Enclosure

---

Suspending any object is potentially dangerous and should only be attempted by individuals who have a thorough knowledge of the techniques and regulations of rigging objects overhead. Electro-Voice strongly recommends that the MH640P be suspended taking into account all current national, federal, state and local regulations. It is the responsibility of the installer to ensure the MH640P is safely installed in accordance with all such regulations. If the MH640P is suspended, Electro-Voice strongly recommends that the system be inspected at least once a year. If any sign of weakness or damage is detected, remedial action should be taken immediately.

The MH640P can be suspended using the two front brackets and the rear "U" bracket

1. Kevlar is a registered trademark of DuPont

# MH640P Full Range Horn System with Passive Crossover

(see Figure 5). The rear "U" bracket must be screwed to the rear cover with the bolts provided. Each of the mounting brackets contain a 3/4-in.-diameter hole through which a shackle or chain link could pass. The MH640P can be oriented in any direction. Electro-Voice strongly recommends that each MH640P be suspended independently using at least three of the four suspension points provided.

**CAUTION:** The MH640P speaker systems should be suspended overhead only in accordance with the procedures and limitations specified in the installation manual included with the systems.

## Connections

Each frequency section can be individually connected via #10 screw terminals. All drivers are connected with the same polarity. A positive voltage applied to the positively marked terminal produces a positive acoustic pressure at the front of the system.

## Crossover

The MH640P comes equipped with a built in passive crossover for easy full range operation from a single amplifier channel. For best performance in your installation broadband equalization is recommended. If desired the MH640P can be easily wired for bi-amplified operation, refer to the MH640C specification sheet for active crossover recommendations.

## Frequency Response

The MH640P axial frequency response was measured in Electro-Voice's large anechoic chamber at a distance of 3 meters (10 feet) with a swept sine-wave input (see Figure 4). It has been normalized for 1 watt/1 meter into the mid-bass section.

## Directivity

The directional characteristics of the MH640P were measured in Electro-Voice's large anechoic chamber, with a test signal of one-third-octave filtered pink noise at the frequencies indicated. A full spherical measurement system, which is fully compatible with Electro-Voice Audio's AcoustaCADD™ computer-aided design

program, was used. All directional information was measured at 6.1 meters (20 feet).

Figure 1 illustrates the nominal horizontal and vertical polar responses, with the long system axis vertical. If the mid-bass/high-frequency module is rotated, then the horizontal and vertical polars should be interchanged.

Figure 2 illustrates the horizontal and vertical beamwidths. Beamwidth is the angle at which the horizontal and vertical polar responses have decreased in level by 6 dB when compared to the on-axis frequency response.

Figure 3 represents the total directivity of the MH640P. The directivity factor  $R_0$  (Q) is the relative value, at a point, when compared to an ideal spherical response. The directivity index ( $D_i$ ) is calculated by  $D_i = 10 \log_{10} R_0$ .

## Service

In the unlikely event the MH640P requires service, each driver can be replaced or repaired. A service data sheet is available from Electro-Voice.

## Power Handling Capacity

Electro-Voice components and systems are manufactured to exacting standards, ensuring they will hold up, not only through the most rigorous of power tests, but also through continued use in arduous, real-life conditions. The EIA Loudspeaker Power Rating Full Range (ANSI/EIA RS-426-A 1980) was used. The specification uses random-noise spectrums which mimic typical music and test the thermal and mechanical capabilities of the components. Extreme, in-house power tests, which push the performance boundaries of the components, are also performed and passed to ensure years of trouble-free service.

The MH640P passes ANSI/EIA RS-426-A 1980 with the following values:

$$R_{SR} = 6.9 \text{ ohms } (1.15 \times R_E)$$

$$P_{E(MAX)} = 300 \text{ watts}$$

$$\text{Test voltage} = 45.5 \text{ volts rms,}$$

$$91.0 \text{ volts peak (+6 dB)}$$

## Architects' and Engineers' Specifications

The loudspeaker system shall be a two-way, horn-loaded, with built in passive cross-over. The mid-bass frequencies shall be reproduced by a single DL10X SH 25.4-cm (10-in.) driver coupled to a MH640P 60° x 40° constant-directivity horn. The high frequencies shall be reproduced by a 60-watt DH2As2 2-inch compression driver coupled to an HP64 60° x 40° constant-directivity horn. The mid-bass and high-frequency devices shall be coaxially mounted. The system will reproduce frequencies from 140 to 20,000 Hz and have a nominal coverage pattern of 60° x 40°. The directivity control shall be maintained down to 500 Hz. The crossover frequency shall be 1,600 Hz. The module shall be capable of producing average sound levels in excess of 128 dB (1 watt/1 meter) in the long term, with short-term peaks of 134 dB. Provision shall be made to provide four safe suspension points, made from 10-gauge steel.

The dimensions shall be 68.6 cm (27.0 in.) tall, 68.6 cm (27.0 in.) wide, and 71.1 cm (28.0 in.) deep. Weight shall be 33.6 kg (74 lb).

The loudspeaker system shall be the Electro-Voice MH640P.

## Limited Warranty

Electro-Voice products are guaranteed against malfunction due to defects in materials or workmanship for a specified period, as noted in the individual product-line statement(s) below, or in the individual product data sheet or owner's manual, beginning with the date of original purchase. If such malfunction occurs during the specified period, the product will be repaired or replaced (at our option) without charge. The product will be returned to the customer prepaid. **Exclusions and Limitations:** The Limited Warranty does not apply to: (a) exterior finish or appearance; (b) certain specific items described in the individual product-line statement(s) below, or in the individual product data sheet or owner's manual; (c) malfunction resulting from use or operation of the product other than as specified in the product data sheet or owner's manual; (d) malfunction resulting from misuse or abuse

## MH640P Full Range Horn System with Passive Crossover

of the product; or (e) malfunction occurring at any time after repairs have been made to the product by anyone other than Electro-Voice Service or any of its authorized service representatives. **Obtaining Warranty Service:** To obtain warranty service, a customer must deliver the product, prepaid, to Electro-Voice Service or any of its authorized service representatives together with proof of purchase of the product in the form of a bill of sale or receipted invoice. A list of authorized service representatives is available from Electro-Voice Service at 600 Cecil Street, Buchanan, MI 49107 (800/234-6831 or FAX 616/695-4743). **Incidental and Consequential Damages Excluded:** Product repair or replacement and return to the customer are the only remedies provided to the customer. Electro-Voice shall not be liable for any incidental or consequential damages including, without limitation, injury to persons or property or loss of use. Some states do not allow the exclusion or

limitation of incidental or consequential damages so the above limitation or exclusion may not apply to you. **Other Rights:** This warranty gives you specific legal rights, and you may also have other rights which vary from state to state.

**Electro-Voice Speakers and Speaker Systems** are guaranteed against malfunction due to defects in materials or workmanship for a period of five (5) years from the date of original purchase. The Limited Warranty does not apply to burned voice coils or malfunctions such as cone and/or coil damage resulting from improperly designed enclosures. Electro-Voice active electronics associated with the speaker systems are guaranteed for three (3) years from the date of original purchase. Additional details are included in the Uniform Limited Warranty statement.

**Electro-Voice FlyingHardware** (including enclosure-mounted hardware and rigging accessories) is guaranteed against malfunc-

tion due to defects in materials or workmanship for a period of one (1) year from the date of original purchase. Additional details are included in the Uniform Limited Warranty statement.

**Electro-Voice Accessories** are guaranteed against malfunction due to defects in materials or workmanship for a period of one (1) year from the date of original purchase. Additional details are included in the Uniform Limited Warranty statement.

**For warranty repair** or service information, contact the service repair department at: 616/695-6831 or 800/685-2606.

**For technical assistance,** contact Technical Support at 800/234-6831 or 616/695-6831, M-F, 8:00 a.m. to 5:00 p.m. Eastern Standard Time.

Specifications subject to change without notice.

# MH640P Full Range Horn System with Passive Crossover

Figure 1—Polars

— HORIZONTAL  
- - VERTICAL  
5 dB per division

MH640P Passive Crossover Full Range Horn System

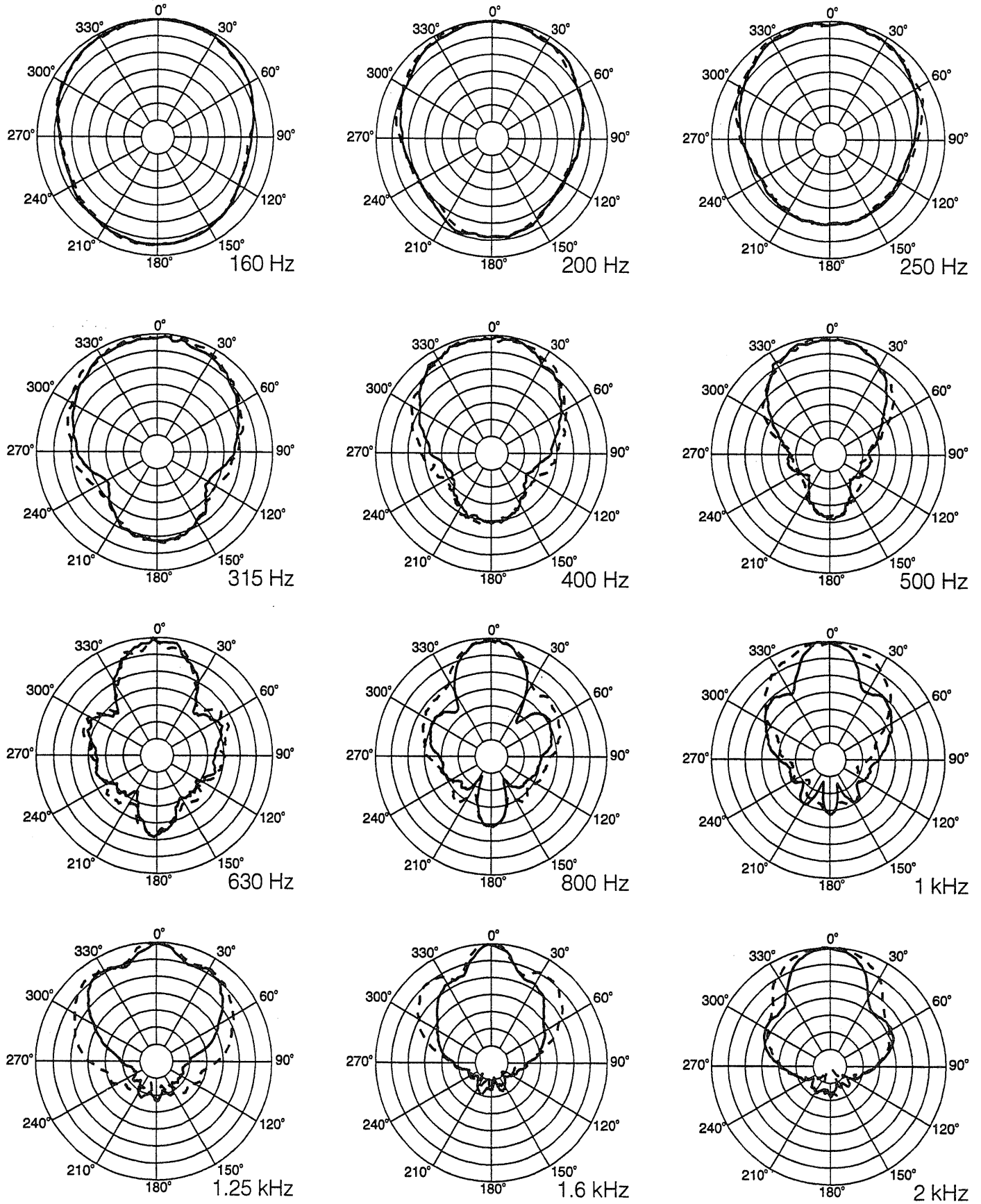

# MH640P Full Range Horn System with Passive Crossover

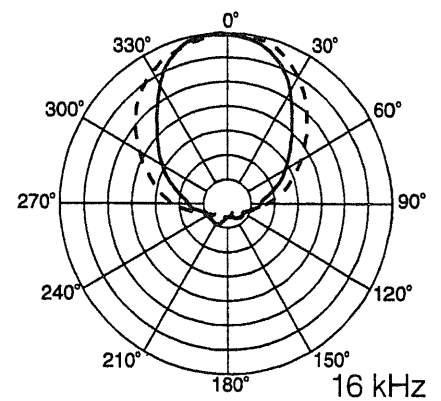
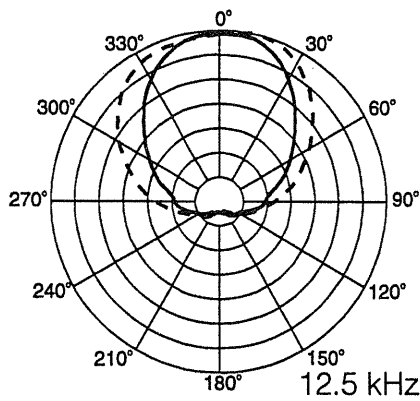
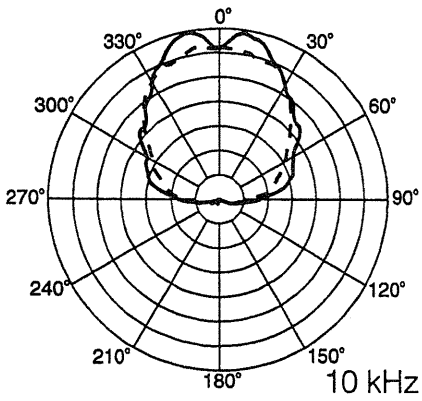
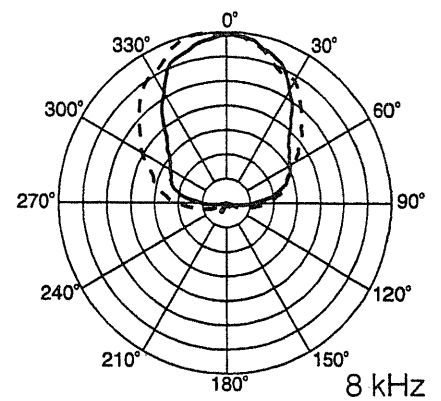
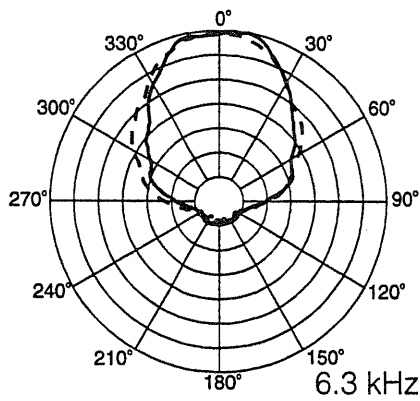
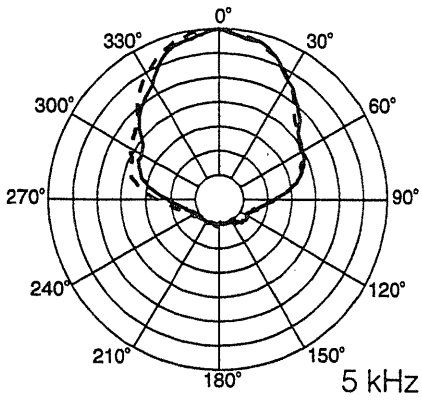
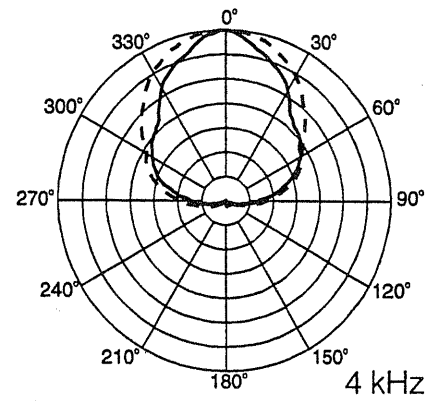
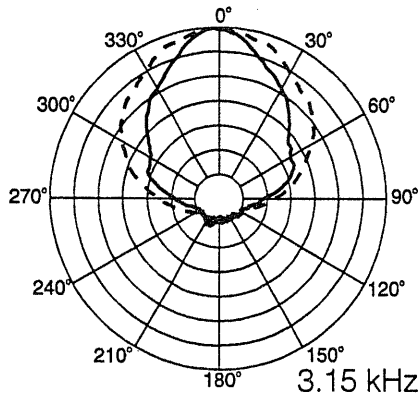
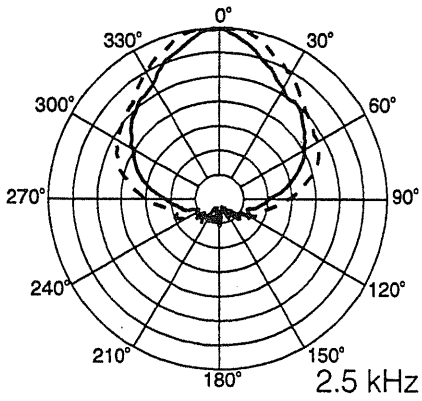

MH640P Passive Crossover Full Range Horn System

# MH640P Full Range Horn System with Passive Crossover

Figure 2—Beamwidth vs. Frequency

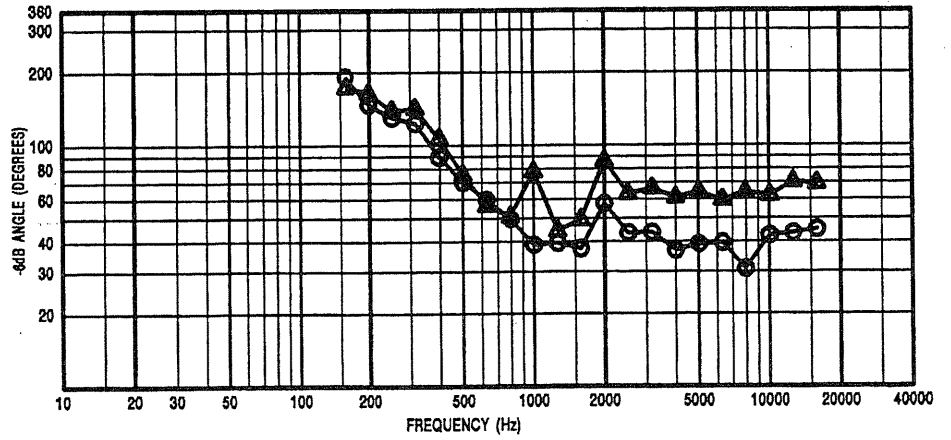

Figure 3—Directivity Factor and Directivity Index vs. Frequency

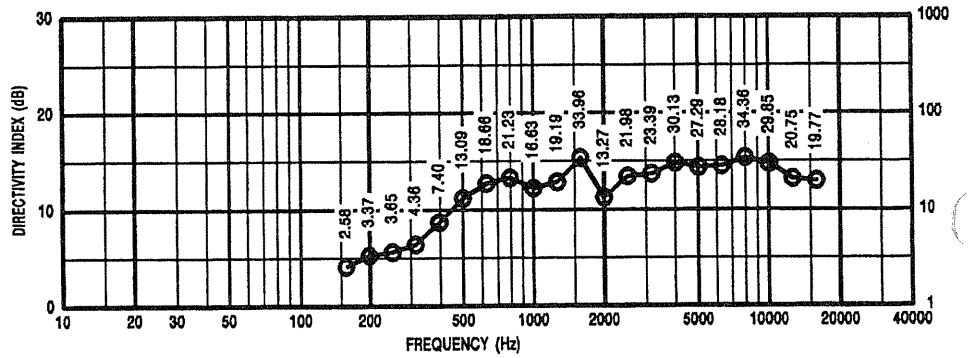
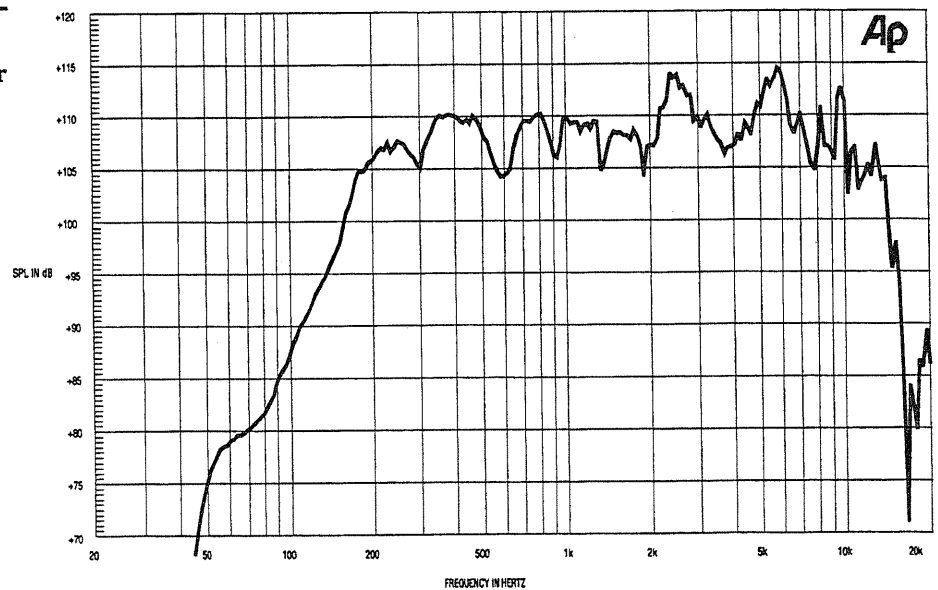
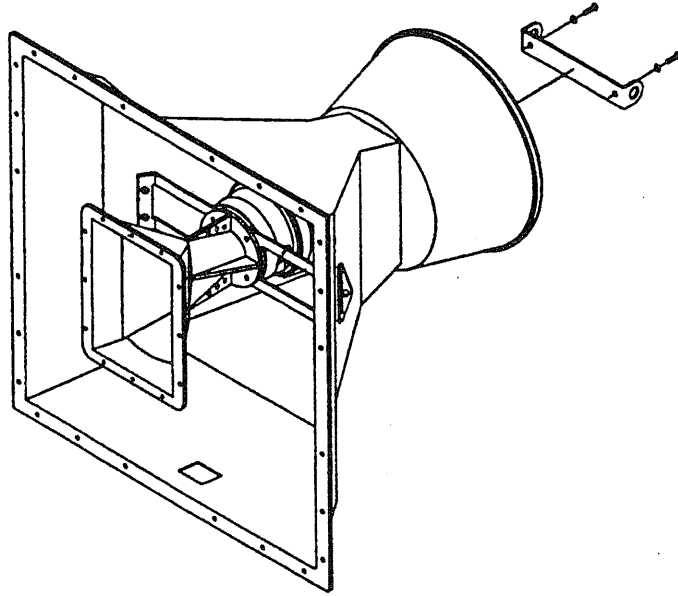

Figure 4—Axial Frequency Response (anechoic environment, 1 watt/1 meter into mid-bass section)



# MH640P Full Range Horn System with Passive Crossover

Figure 5—Hanging Points



# MH640P Full Range Horn System with Passive Crossover

## Specifications:

### Useable Frequency Response

(see Figure 4):

150-20,000 Hz

### Power Handling:

Long term average broadband per EIA RS-426A, (See page 2 for complete test description):

300 watts.

### Sensitivity:

Sound Pressure Level @ 1 Meter, 2.83

Volts input, band limited pink noise in anechoic environment:

109 dB

### Average Efficiency:

Mid Bass:

25%

High Frequency:

25%

### Nominal Coverage Angle

(See figure 2),

Horizontal:

60°

Vertical:

40°

### Mid-bass Transducer:

DL10A-SH, with water resistant cone and Ring-Mode Decoupling

### High Frequency Transducer:

DH2As2 compression driver on HP64 60 x 40 horn coaxially mounted to mid bass horn.

### Nominal Impedance in pass band,

Mid Bass:

16 ohms

High Frequency:

8 ohms

Full Range:

8 ohms

### D.C. Resistance,

Mid-bass:

6.2 Ohms

High Frequency:

5.8 ohms

Full-Range:

7.2 ohms

### Construction:

One-Piece black polyester and fiberglass with composite reinforcement

### Driver Input Connections:

Screw terminals (#10) on barrier strip.

### Driver Polarity:

A positive voltage applied to the positive leads produces a positive acoustic pressure.

### Hanging Hardware:

4 Point, black, 10-gauge polyester powder-coated steel

### Dimensions:

Height:

68.6 cm (27.0 in.)

Width:

68.6 cm (27.0 in.)

Length:

71.1 cm (28.0 in.)

### Weight:

27.2 kg (60 lb)

### Shipping Weight:

33.6 kg (74 lb)

# Electro-Voice®

600 Cecil Street, Buchanan, MI 49107

616/695-6831, 616/695-1304 Fax