

MH660C Coaxial Constant-Directivity Horn System

- High-output high-quality music and speech for stadiums and performing-arts venues
- Large, correctly sized horn mouths provide uniform directivity control to 500 Hz, for increased intelligibility under difficult acoustic conditions
- High "Q" for increased intelligibility
- Suspension system for safe and easy installation
- DH2As2 2-inch compression driver for extended high-frequency performance
- Short throw/fill-in when used with the very-large-format MH stadium horn systems
- 6.0 degree vertical coverage angle

SPECIFICATIONS

Typical Axial Frequency Response (swept one-third-octave pink noise, anechoic environment, 4 volts at 10 feet, normalized for 1 watt, 1 meter into mid-bass driver; see Figure 1):

150-20,000 Hz

Low-Frequency 3-dB-Down Point:

150 Hz

Usable Low-Frequency Limit (10-dB-down point):

140 Hz

Recommended Crossover Frequencies:

160 Hz, 1,600 Hz

Crossover Slopes per Octave, Suggested:

24 dB

Recommended Signal Delay,

Mid Bass: 0.00 msec

High Frequency: 0.60 msec

Long-Term Average Power-Handling Capacity (see Power Handling section),

Mid Bass

(per ANSI/EIA RS-426-A):

300 watts

High Frequency

(per AES2-1984/ANSI S4.26-1984):

60 watts

Sensitivity (SPL at 1 meter, 1 watt input, anechoic environment, band-limited pink-noise signal),

Mid Bass: 107 dB

High Frequency: 111 dB

Impedance,

Nominal (mid bass/high frequency):

16 ohms/8 ohms

Minimum (mid bass/high frequency):

11 ohms/6 ohms

Average Efficiency,

Mid Bass:

25%

High Frequency:

25%

Maximum Long-Term Average Mid-Band Acoustic Output:

75 watts

Beamwidth (angle included by 6-dB-down points on polar responses, indicated one-third-octave bands of pink noise; see Figure 2), 600 to 20,000 Hz Horizontal or Vertical:

60 degrees +/- 25

Directivity Factor 500- to 20,000-Hz

Median (see Figure 3):

18.2

Directivity Index D_i, 500- to 20,000-Hz

Median (see Figure 3):

12.6 dB (+3.8 dB, -4.0 dB)

Distortion (120 dB SPL at 1 meter from mid-bass horn using typical music spectrum; see Figure 4),

Second Harmonic,

1,000 Hz: less than 1%

10,000 Hz: less than 1%

Third Harmonic,

1,000 Hz: less than 1%

10,000 Hz: less than 1%

Transducer Complement,

Mid Bass:

DL10X-SH 25.4-cm (10-in.) driver with

Kevlar epoxy composite cone on

rotatable MH660 6.0 x 6.0 degree horn

High Frequency:

DH2As2 compression driver on HP66

6.0 x 6.0 degree horn coaxially mounted

to a mid-bass horn

Polarity (all drivers):

A positive voltage applied to the positively marked input terminal produces a positive acoustic pressure at the front of the system

1. Kevlar is a registered trademark of DuPont.

Input Connections,

Mid Bass/High Frequency:

Screw terminals (#10) on barrier strip; each driver can be individually accessed; high-frequency driver has blocking capacitor for protection

Construction,

Main Horn Bell:

One-piece black polyester and fiberglass laminate with composite reinforcement

Hanging Hardware:

4-point, black, 10-gauge polyester-powder-coated steel

Dimensions,

Height:

68.6 cm (27.0 in.)

Width:

68.6 cm (27.0 in.)

Depth:

71.1 cm (28.0 in.)

Net Weight:

27.2 kg (60 lb)

Shipping Weight:

33.6 kg (74 lb)

DESCRIPTION

The Electro-Voice MH660C is a two-way horn-loaded speaker system for permanent installation. Because the mouth dimensions of both the mid-bass and high-frequency horns were correctly chosen and are large enough with respect to the wavelengths reproduced, the MH660C provides uniform directivity control down to 500Hz. This super directivity control increases speech intelligibility and musical clarity in difficult acoustic environments. **Other horn systems with smaller radiating areas simply cannot provide the high degree of directional control associated with the MH660C.**

MH660C SPECIFICATION GRAPHICS

FIGURE 1 - Typical Axial Frequency Response (anechoic environment, 1 watt/1 meter into mid-bass section)

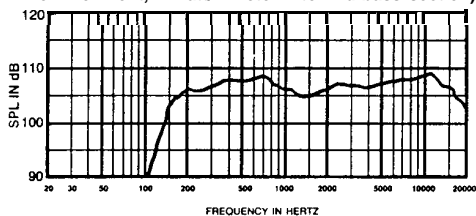

FIGURE 2 - Beamwidth vs. Frequency

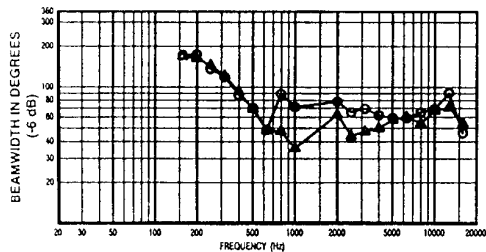

FIGURE 3 - Directivity Factor and Directivity Index vs. Frequency

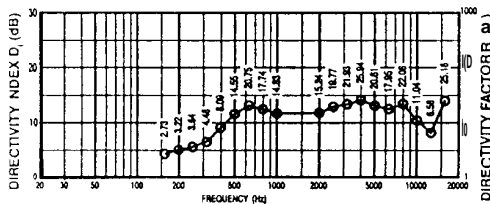

FIGURE 4 - Harmonic Distortion (120 dB SPL at one meter from mid-bass horn using typical music spectrum)

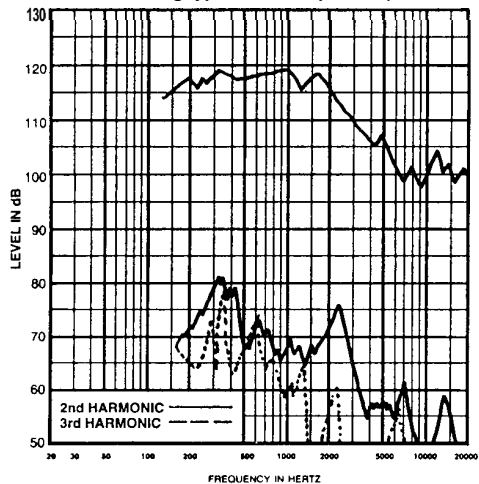

FIGURE 6 - Hanging Points

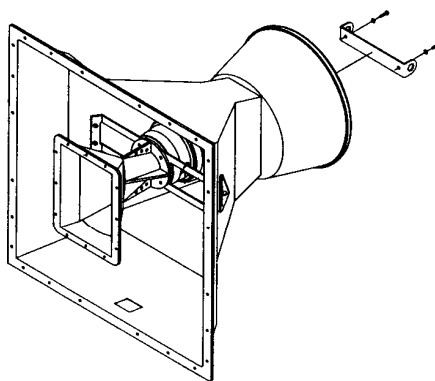
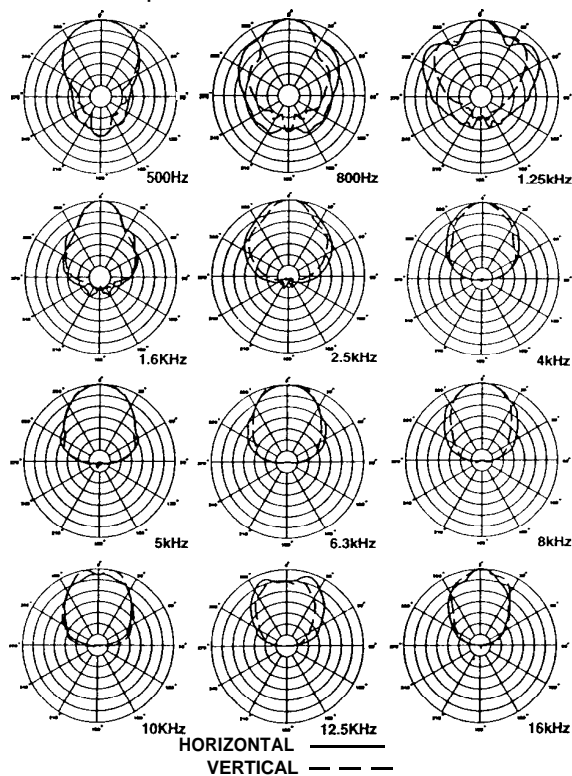

FIGURE 6 - Polar Response



The MH660C is a 60 x 60 deg. two-way system with mid-bass and high-frequency horns that are coaxially mounted. The common acoustic axes of these horns ensures smooth response and coverage in the crossover region when the appropriate signal delay is applied to the high-frequency driver.

Delivering smooth and extended performance, the high-frequency section operates from 1,600 to 20,000 Hz and consists of a specially developed, low-profile DH2As2 compression driver coupled to an HP64 60 x 60 constant-directivity horn. The HP66 horn features integral fiberglass-and-zinc construction for exceptional strength and performance. Beamwidth-control vanes in the horn throat correct all coverage anomalies in the 10-to-20-kHz octave. This horn and driver combination is securely mounted to the mid-bass horn by a heavy-duty steel bracket.

The mid-bass system is composed of a DL10X-SH 24.5-cm (10-in.) reproducer mounted on a MH660 60 x 60 deg. mid-bass horn. The DL10X-SH reproducer contains a Kevlar epoxy cone, which is twice as strong as the conventional paper cone. The mid-bass section operates between 140 and 1,600 Hz, and features a proprietary phase plug (U.S. patent no. 4,718,517) which extends the high-end output to blend seamlessly into the coaxial high-frequency section.

If the MH660C is used in a full-range application, additional low-frequency reinforcement, such as the P11 15L or a TL-series enclosure will be required.

APPLICATIONS

The MH660C has been designed specifically with the permanent installation market in mind. Sports arenas, performing arts centers, auditoriums and large gymnasiums are all candidates for the MH660C. With its superior directivity control, the MH660C is a system that can be used in almost any situation. The concert-sound pedigree of the MH660C is evident by the ease of installation and by the use of professional-grade components throughout the line.

SUSPENDING MH660C ENCLOSURES

Suspending any object is potentially dangerous and should only be attempted by individuals who have a thorough knowledge of the techniques and regulations of rigging objects overhead. Electro-Voice strongly recommends that the MH660C be suspended taking into account all current national, federal, state and local regulations. It is the responsibility of the installer to ensure the MH660C is safely installed in accordance with all such regulations. If the MH660C is suspended, Electro-Voice strongly recommends that the system be inspected at least once a year. If any sign of weakness or damage is detected, remedial action should be taken immediately.

A manual entitled *installing the MH Series* is available from Electro-Voice. It is included with every MH system and should be followed carefully. A general overview is included here to help the system designer. This overview does not replace the *installing the MH Series* manual, which includes additional information on suspending, configuring and equalizing the MH series.

The MH660C can be suspended using the two front brackets and the rear "U" bracket (see Figure 5). The rear "U" bracket must be screwed to the rear cover with the bolts provided. Each of the mounting brackets contains a diameter hole through which a shackle or chain link could pass. The MH660C can be oriented in any direction. Electro-Voice strongly recommends that each MH660C be suspended independently using at least three of the four suspension points provided.

If the MH660C is suspended, it is recommended that the unit be inspected at least once a year. If any sign of weakness is detected, remedial action should be taken immediately.

CAUTION: The MH660C speaker systems should be suspended overhead **only in accordance with the procedures and limitations** specified in the installation manual included with the systems.

CONNECTIONS

Each frequency section can be individually connected via #10 screw terminals. All drivers are connected with the same polarity. A positive voltage applied to the positively marked terminal produces a positive acoustic pressure at the front of the system.

CROSSOVER, EQ AND SIGNAL DELAY

The MH660C is a two-way system which must be biamped with a separate active crossover. 24-dB-per-octave crossover slopes are assumed for maximum performance and reliability. For optimum performance, EQ and signal delay are required. (Note: the delays noted below are for fourth-order (24-dB-per-octave) Linkwitz-Riley crossover filter characteristics.) The mid-bass section should be crossed over to match the low-frequency section and at 1,600 Hz at the high end. No signal delay or overall broadband EQ is required. The high-frequency section requires a 1,600-Hz crossover and the typical constant-directivity-horn high-frequency boost EQ. A 0.6-msec signal delay provides the smoothest response in the crossover region. A low-frequency blocking capacitor with a 3-dB-down point of 800 Hz is included.

An Electro-Voice XEQ-3 electronic crossover/ equalizer/time delay unit with EQW plug-in module provides all of the necessary signal processing. The XEQ-3 is a three-way electronic crossover with adjustable crossover frequencies utilizing Linkwitz-Riley 24-dB-per-octave filters and signal delay equalization to achieve zero lobbing error.

FREQUENCY RESPONSE

The MH660C axial frequency response was measured in Electro-Voice's large anechoic chamber at a distance of 3 meters (10 feet) with a swept sine-wave input (see Figure 1). It has been normalized for 1 watt/l meter into the mid-bass section. Minimal level adjustment and equalization have been used.

DIRECTIVITY

The directional characteristics of the MH660C were measured in Electro-Voice's large anechoic chamber, with a test signal of one-third-octave filtered pink noise at the frequencies indicated. A full spherical measurement system, which is fully compatible with Electro-Voice's AcoustaCADD computer-aided design program, was used. All directional information was measured at 6.1 meters (20 feet).

Figure 6 illustrates the nominal horizontal and vertical polar responses, with the long system axis vertical. If the mid-bass/high-frequency module is rotated, then the horizontal and vertical polars should be interchanged.

Figure 2 illustrates the horizontal and vertical beamwidths. Beamwidth is the angle at which the horizontal and vertical polar responses have decreased in level by 6 dB when compared to the on-axis frequency response.

Figure 3 represents the total directivity of the MH660C. The directivity factor R_0 (Q) is the relative value, at a point, when compared to an ideal spherical response. The directivity index (D_i) is calculated by $D_i = 10 \log_{10} R_0$.

SERVICE

In the unlikely event the MH660C requires service, each driver can be replaced or repaired. A service data sheet is available from Electro-Voice.

POWER-HANDLING TEST

Electro-Voice components and systems are manufactured to exacting standards, ensuring they will hold up, not only through the most rigorous of powertests, but also through continued use in arduous, real-life conditions. Two main test specifications are used: the AES Recommended Practice for Specification of Loudspeaker Components Used in Professional Audio and Sound Reinforcement (AES2-1984/ANSI S4.26-1984) and the EIA Loudspeaker Power Rating Full Range (ANSI/EIA RS-426-A 1980). Both of these specifications use random-noise spectrums which mimic typical music and test the thermal and mechanical capabilities of the components. Electro-Voice will support relevant additional standards as and when they become available. Extreme, in-house power tests, which push the performance boundaries of the components, are also performed and passed to ensure years of trouble-free service.

Specifically, the MH660C high-frequency section passes AES2-1984/ANSI S4.26-1984 with the following values:

$Z_{MIN} = 6.0$ ohms at 7,000 Hz
 $P = 60$ watts
Test Voltage = 19.0 volts rms,
38.0 volts peak (+6 dB)
Selected decade = 1,500-15,000 Hz

The MH660C mid-bass section passes ANSI/EIA RS-426-A 1980 with the following values:

$R_{SR} = 6.9$ ohms (1.15 x R_E)
 $P = 300$ watts
Test Voltage = 45.5 volts rms,
91.0 volts peak (+6 dB)

ARCHITECTS' AND ENGINEERS' SPECIFICATIONS

The loudspeaker system shall be a two-way, active, horn-loaded type. The mid-bass frequencies shall be reproduced by a single DL10X-SH 25.4-cm (10-in.) driver coupled to a MH660 60 x 60 deg. constant-directivity horn. High frequencies shall be reproduced by a 60-watt DH2As2 2-inch compression driver coupled to an HP66 60x60 deg. constant-directivity horn. The mid-bass and high-frequency devices shall be coaxially mounted. The system will reproduce frequencies from 140 to 20,000 Hz and have a nominal coverage pattern of 60 x 60 deg. The directivity control shall be maintained down to 500 Hz. The crossover frequency shall be 1,600 Hz. The module shall be capable of producing average sound levels in excess of

1. Kevlar is a registered trademark of Dupont.

128 dB (1 watt/1 meter) in the long term, with short-term peaks of 134dB. Provision shall be made to provide four safe suspension points, made from 10-gauge steel.

The dimensions shall be 68.6 cm (27.0 in.) tall, 68.6 cm (27.0 in.) wide, and 71.1 cm (28.0 in.) deep. Weight shall be 33.6 kg (74 lb).

The loudspeaker system shall be the Electro-Voice MH660C.

UNIFORM LIMITED WARRANTY

Electro-Voice products are guaranteed against malfunction due to defects in materials or workmanship for a specified period, as noted in the individual product-line statement(s) below, or in the individual product data sheet or owner's manual, beginning with the date of original purchase. If such malfunction occurs during the specified period, the product will be repaired or replaced (at our option) without charge. The product will be returned to the customer prepaid. Exclusions and Limitations: The Limited Warranty does not apply to: (a) exterior finish or appearance; (b) certain specific items described in the individual product-line statement(s) below, or in the individual product data sheet or owner's manual; (c) malfunction resulting from use or operation of the product other than as specified in the product data sheet or owners manual; (d) malfunction re-

sulting from misuse or abuse of the product; or (e) malfunction occurring at any time after repairs have been made to the product by anyone other than Electro-Voice or any of its authorized service representatives. Obtaining **Warranty Service:** To obtain warranty service, a customer must deliver the product, prepaid, to Electro-Voice or any of its authorized service representatives togetherwith proof of purchase of the product in the form of a bill of sale or receipted invoice. A list of authorized service representatives is available from Electro-Voice at 600 Cecil Street, Buchanan, MI 49107(616/6956831 or 800/234-6831). **Incidental and Consequential Damages Excluded:** Product repair or replacement and return to the customer are the only remedies provided to the customer. Electro-Voice shall not be liable for any incidental or consequential damages including, without limitation, injury to persons or property or loss of use. Some states do not allow the exclusion or limitation of incidental or consequential damages so the above limitation or exclusion may not apply to you. Other Rights: This warranty gives you specific legal rights, and you may also have other rights which vary from state to state.

Electro-Voice Speakers and Speaker Systems are guaranteed against malfunction due to defects in materials or workmanship for a period of five (5) years from the date of original

purchase. The Limited Warranty does not apply to burned voice coils or malfunctions such as cone and/or coil damage resulting from improperly designed enclosures. Electro-Voice active electronics associated with the speaker systems are guaranteed for three (3) years from the date of original purchase. Additional details are included in the Uniform Limited Warranty statement.

Electro-Voice Flying Hardware(including enclosure-mounted hardware and rigging accessories) is guaranteed against malfunction due to defects in materials or workmanship for a period of one (1) year from the date of original purchase. Additional details are included in the Uniform Limited Warranty statement.

Electro-Voice Accessories are guaranteed against malfunction due to defects in materials or workmanship for a period of one (1) year from the date of original purchase. Additional details are included in the Uniform Limited Warranty statement.

Service and repair address for this product: Electro-Voice, Inc., 600 Cecil Street, Buchanan, Michigan 49107 or 6831).

Specifications subject to change without notice.